

# Wyoming 4-H

## Wyoming 4-H Showmanship (Intermediate)-2

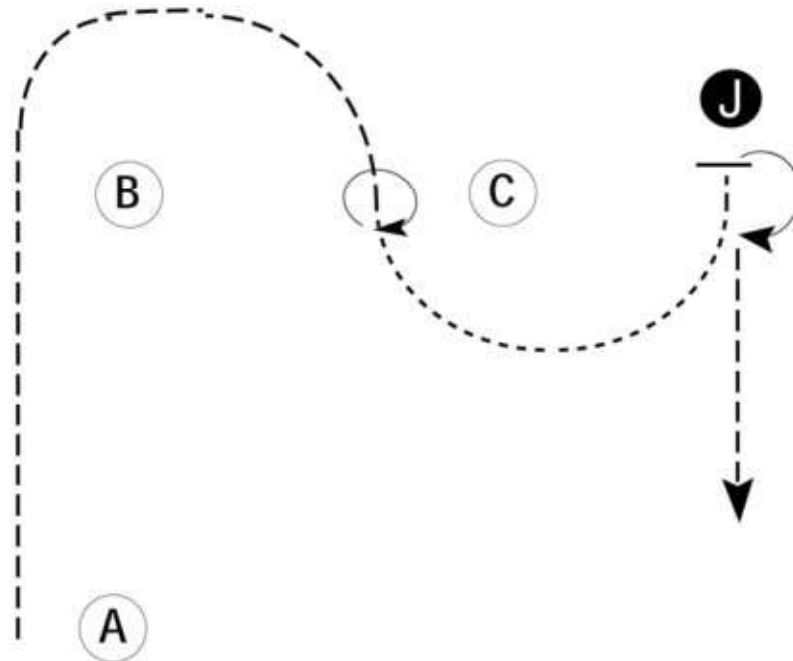

Be ready at A.

1. Trot from A around B and to C.
2. Stop and perform a 360 degree turn.
3. Walk to the Judge. Stop and set up for inspection.
4. When dismissed perform a 180 degree turn and trot straight away from the Judge.

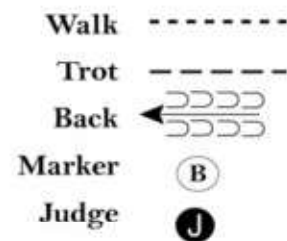

**Pattern Provided by:**

*Wyoming 4-H*

# Wyoming 4-H

## Wyoming 4-H Showmanship (Junior)-3

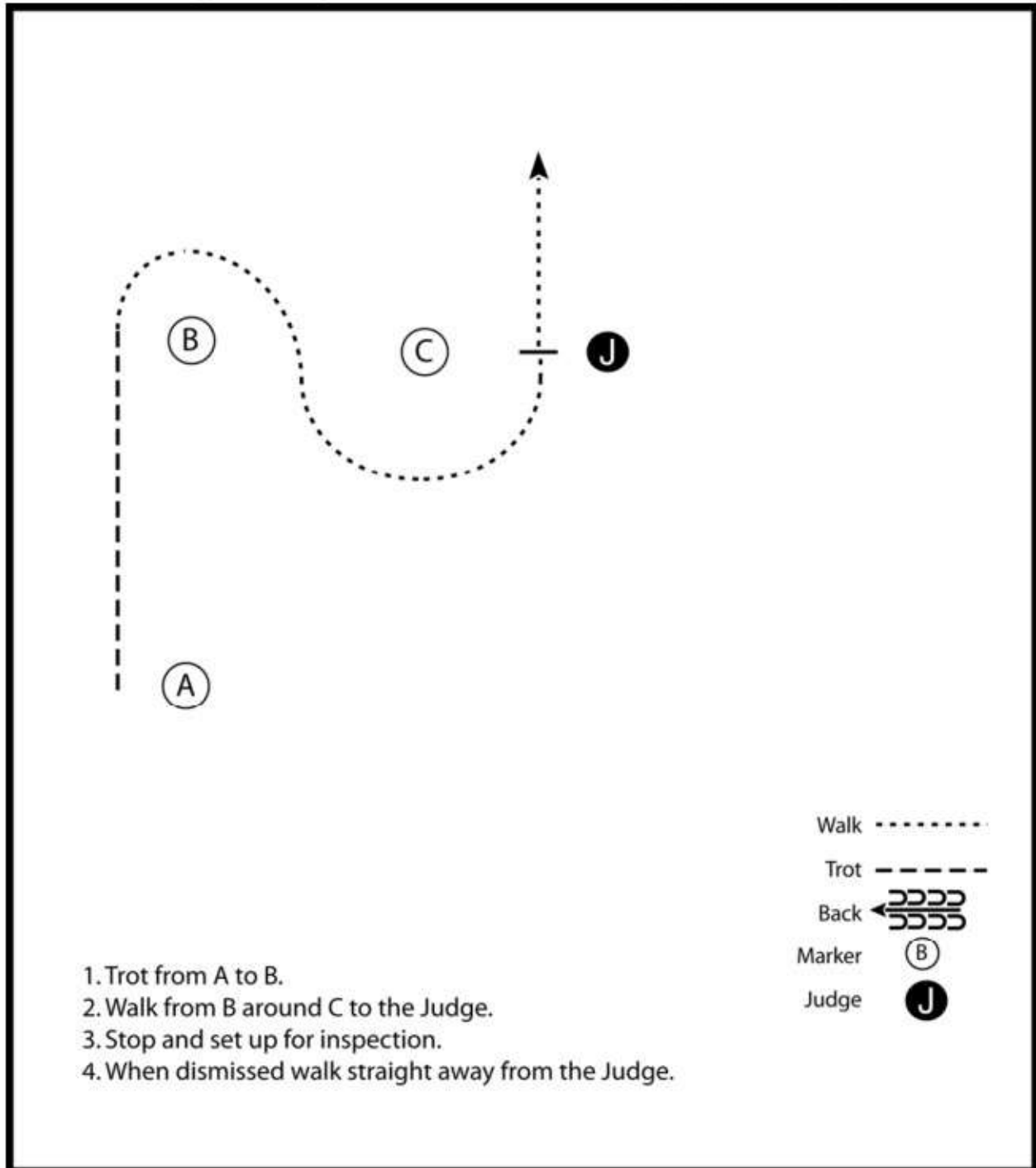

Pattern Provided by:

*Wyoming 4-H*

# Wyoming 4-H

## Wyoming 4-H Showmanship (Senior)-1

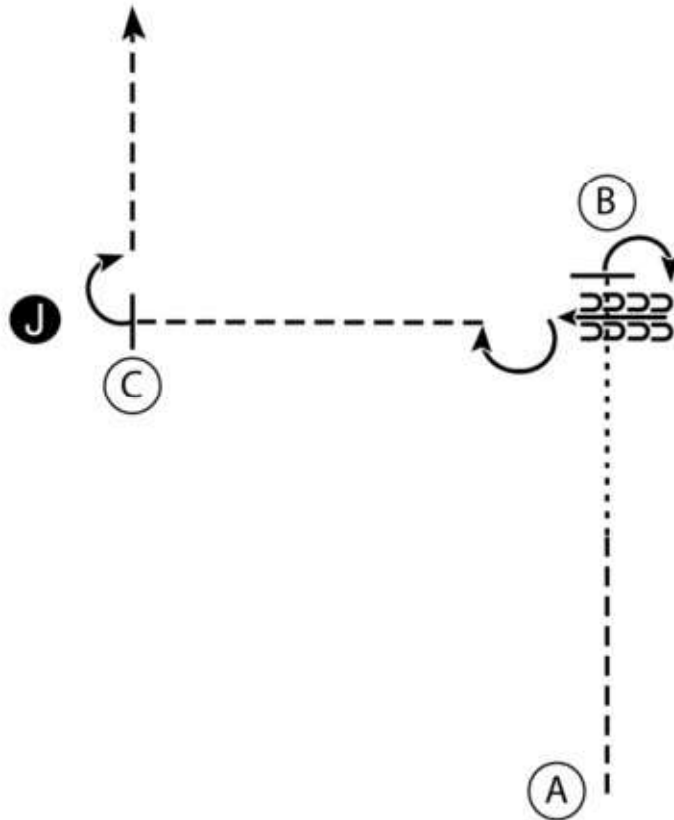

1. Trot from A half way to B.
2. Break to walk and walk to B.
3. Stop and perform a 90 degree turn.
4. Back four steps and perform a 180 degree turn.
5. Trot to C. Stop and set up for inspection.
6. When dismissed perform a 90 degree turn.
7. Trot to line-up.

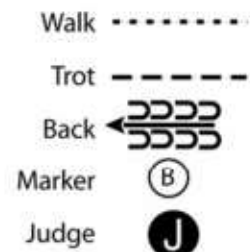

Pattern Provided by:

*Wyoming 4-H*

# Wyoming 4-H

## Wyoming 4-H Showmanship (Senior)-2

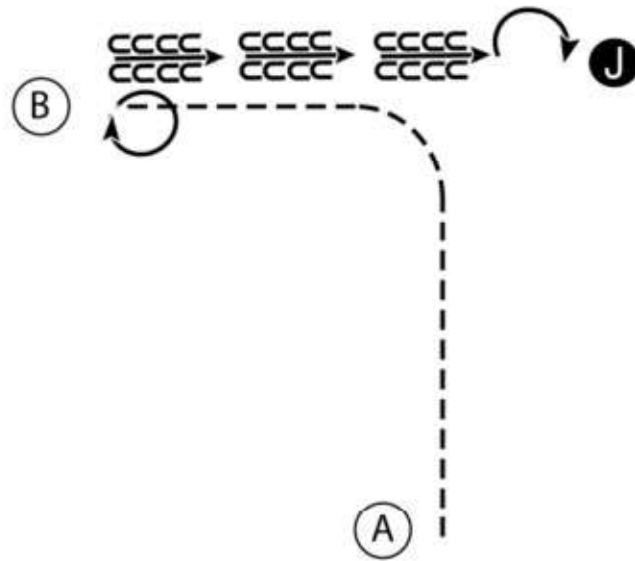

1. Trot from A to B.
2. Stop and perform a 360 degree turn.
3. Back to the Judge, perform a 180 degree turn and set up for inspection.
4. When dismissed follow instructions from the ring steward.

Walk .....  
Trot - - - - -  
Back ←   
Marker (B)  
Judge (J)

**Pattern Provided by:**

*Wyoming 4-H*

# Wyoming 4-H

## Wyoming 4-H Showmanship (Senior)-3

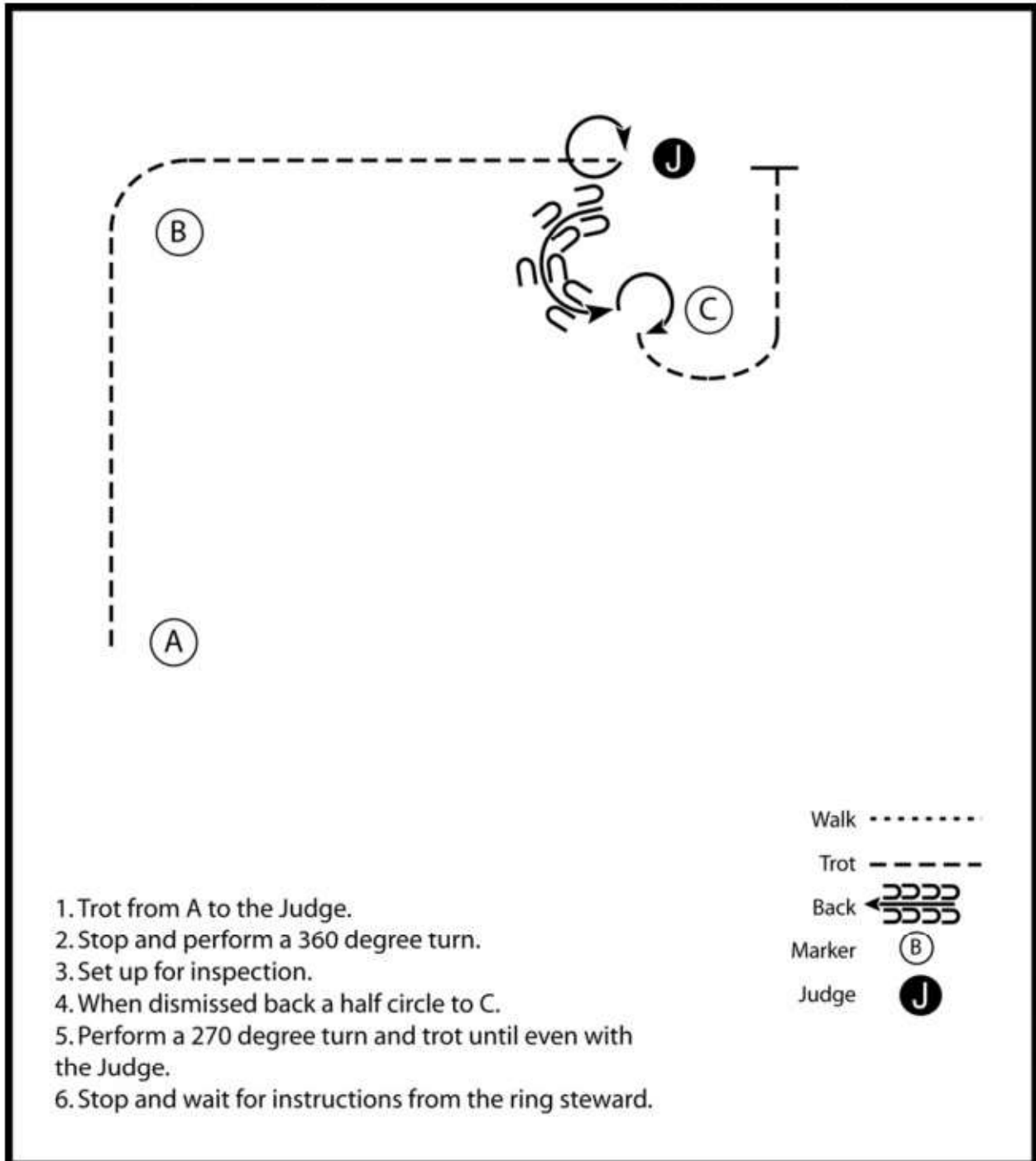

**Pattern Provided by:**

*Wyoming 4-H*

# Wyoming 4-H

## Wyoming 4-H Showmanship (Senior)-4

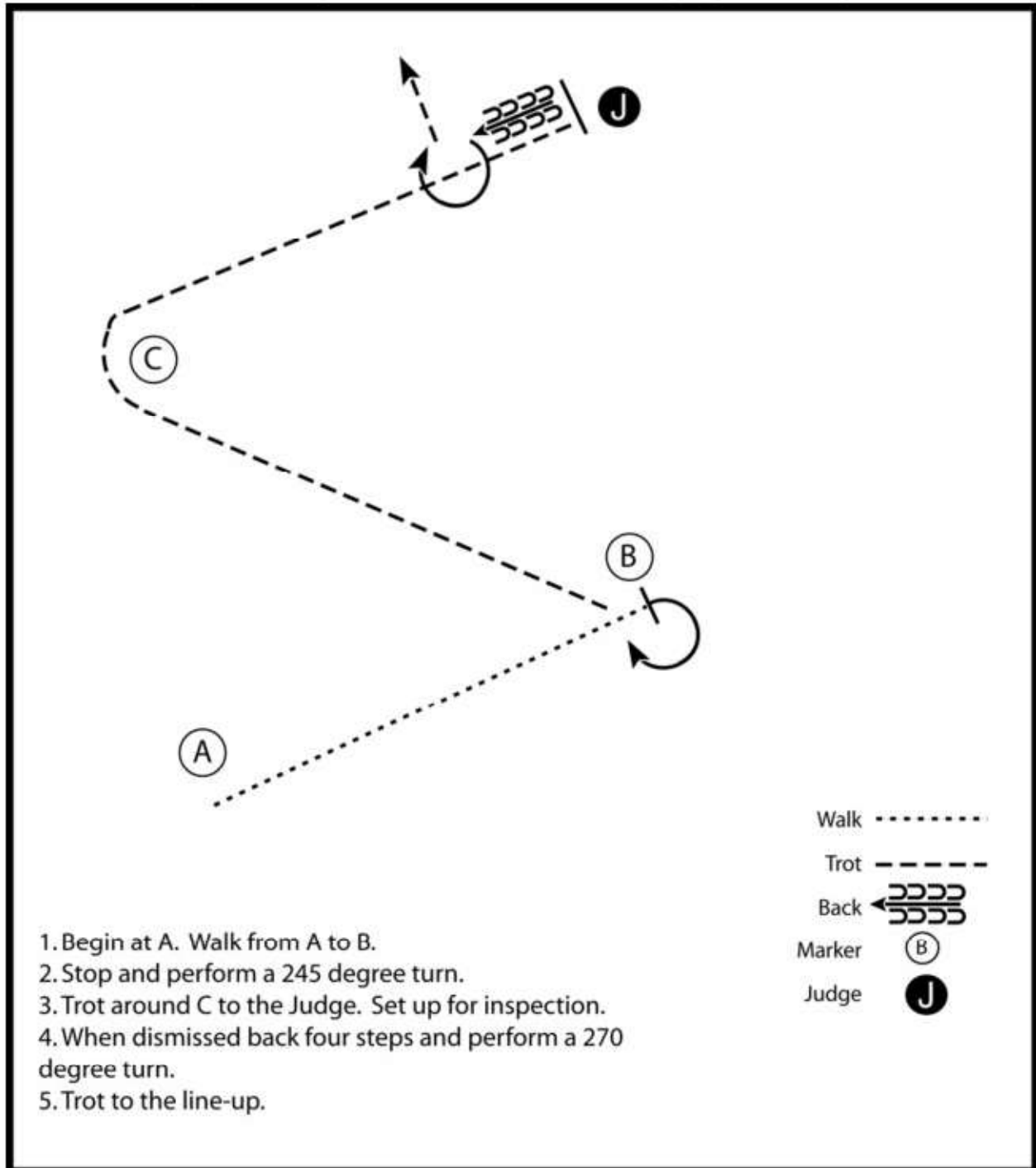

Pattern Provided by:

*Wyoming 4-H*

# Wyoming 4-H

## Wyoming 4-H Showmanship (Senior)-5

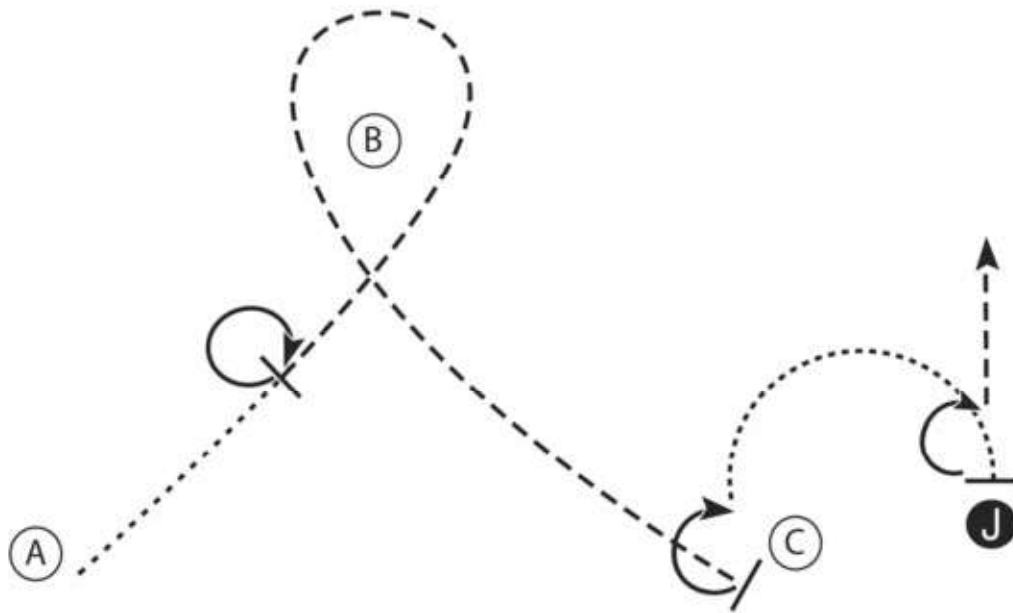

1. Walk A towards B
2. When halfway to B stop and perform a 360 degree turn
3. Trot to and around B and continue to C
4. At C stop and perform a 225 degree turn
5. Walk in a half circle to the judge
6. Stop and set up for inspection
7. When dismissed perform a 180 degree turn and trot straight away from the judge

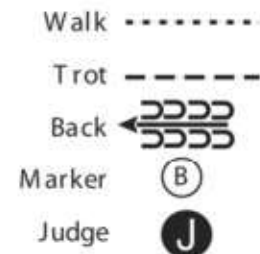

**Pattern Provided by:**

*Wyoming 4-H*

# Wyoming 4-H

## Wyoming 4-H Showmanship (Senior)-6

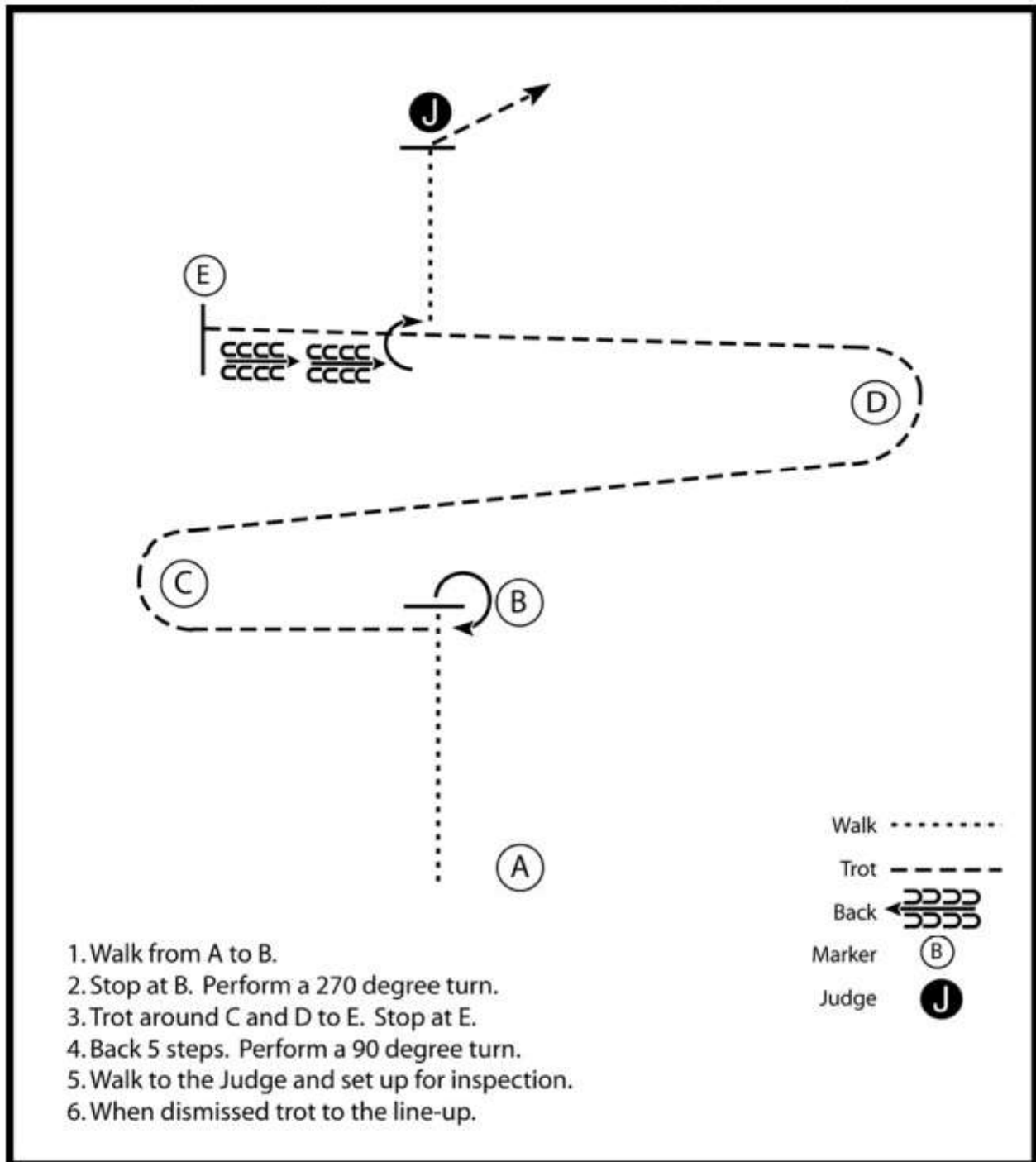

Pattern Provided by:

*Wyoming 4-H*

# Wyoming 4-H

## Wyoming 4-H Showmanship (Senior)-5

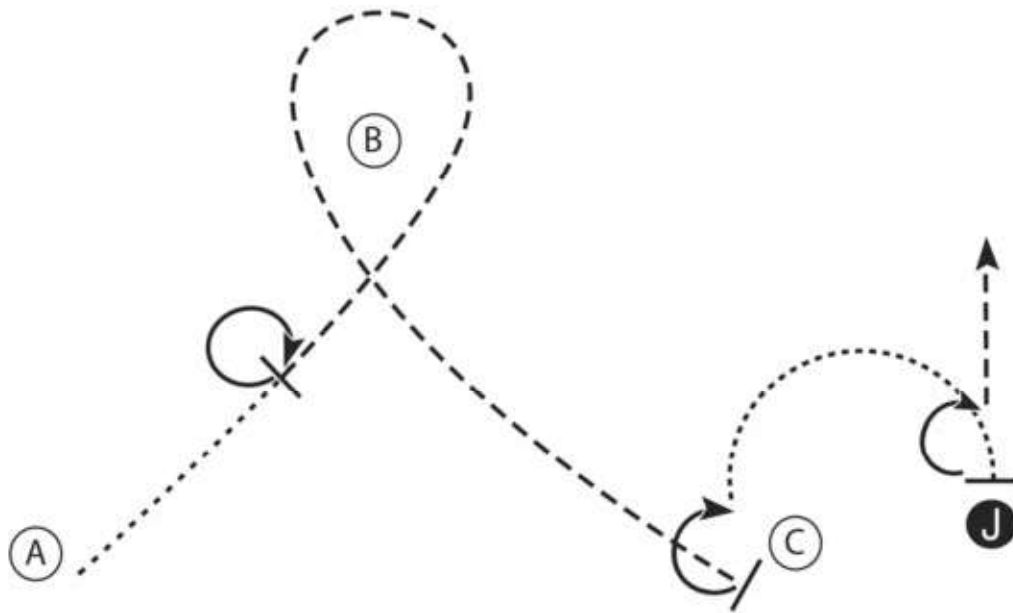

1. Walk A towards B
2. When halfway to B stop and perform a 360 degree turn
3. Trot to and around B and continue to C
4. At C stop and perform a 225 degree turn
5. Walk in a half circle to the judge
6. Stop and set up for inspection
7. When dismissed perform a 180 degree turn and trot straight away from the judge

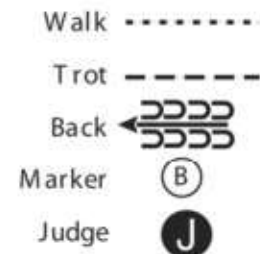

**Pattern Provided by:**

*Wyoming 4-H*

# Wyoming 4-H

## Wyoming 4-H Showmanship (Senior)-6

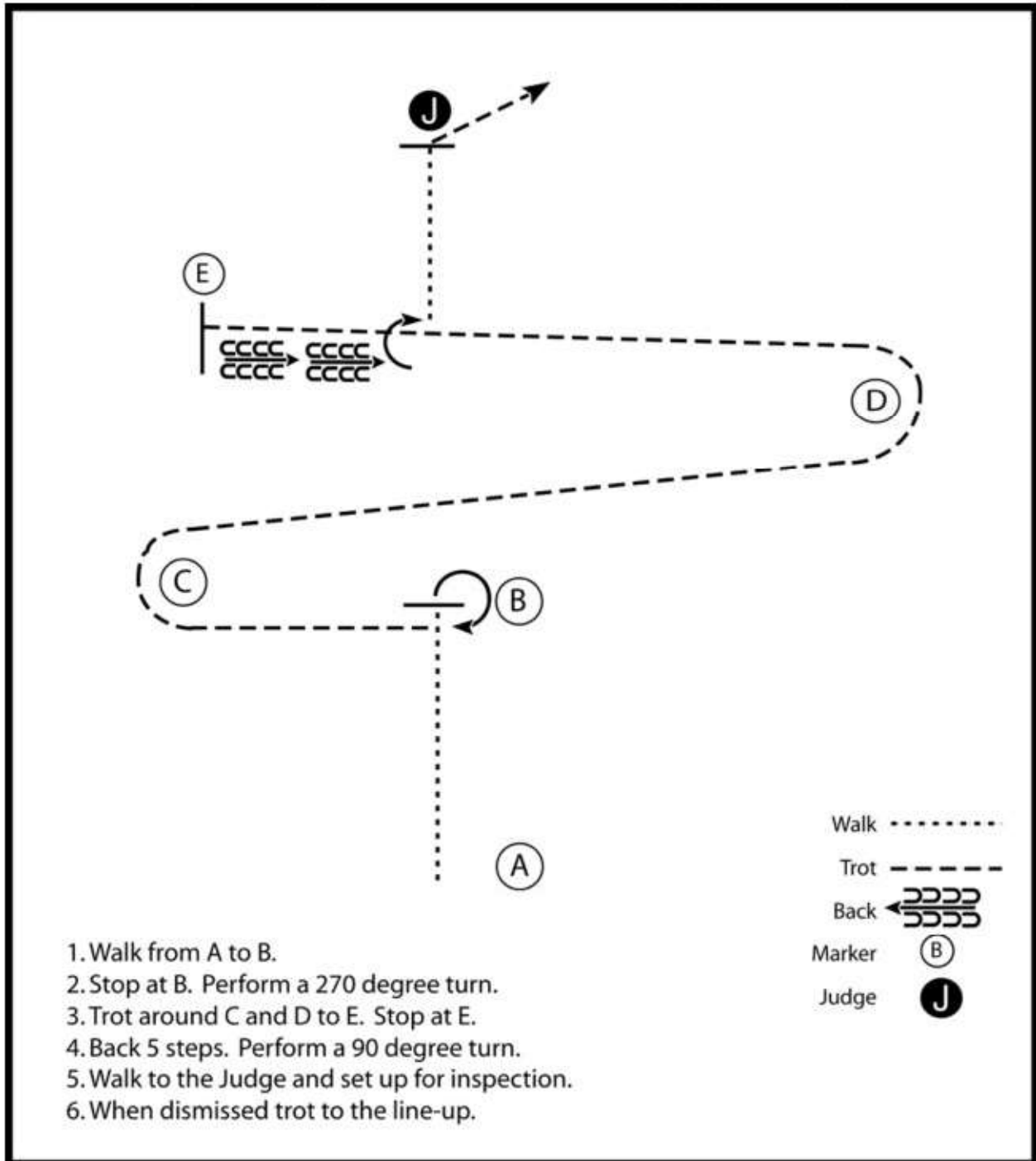

Pattern Provided by:

*Wyoming 4-H*

# Wyoming 4-H

## Wyoming 4-H Hunt Seat Equitation (Intermediate) -1

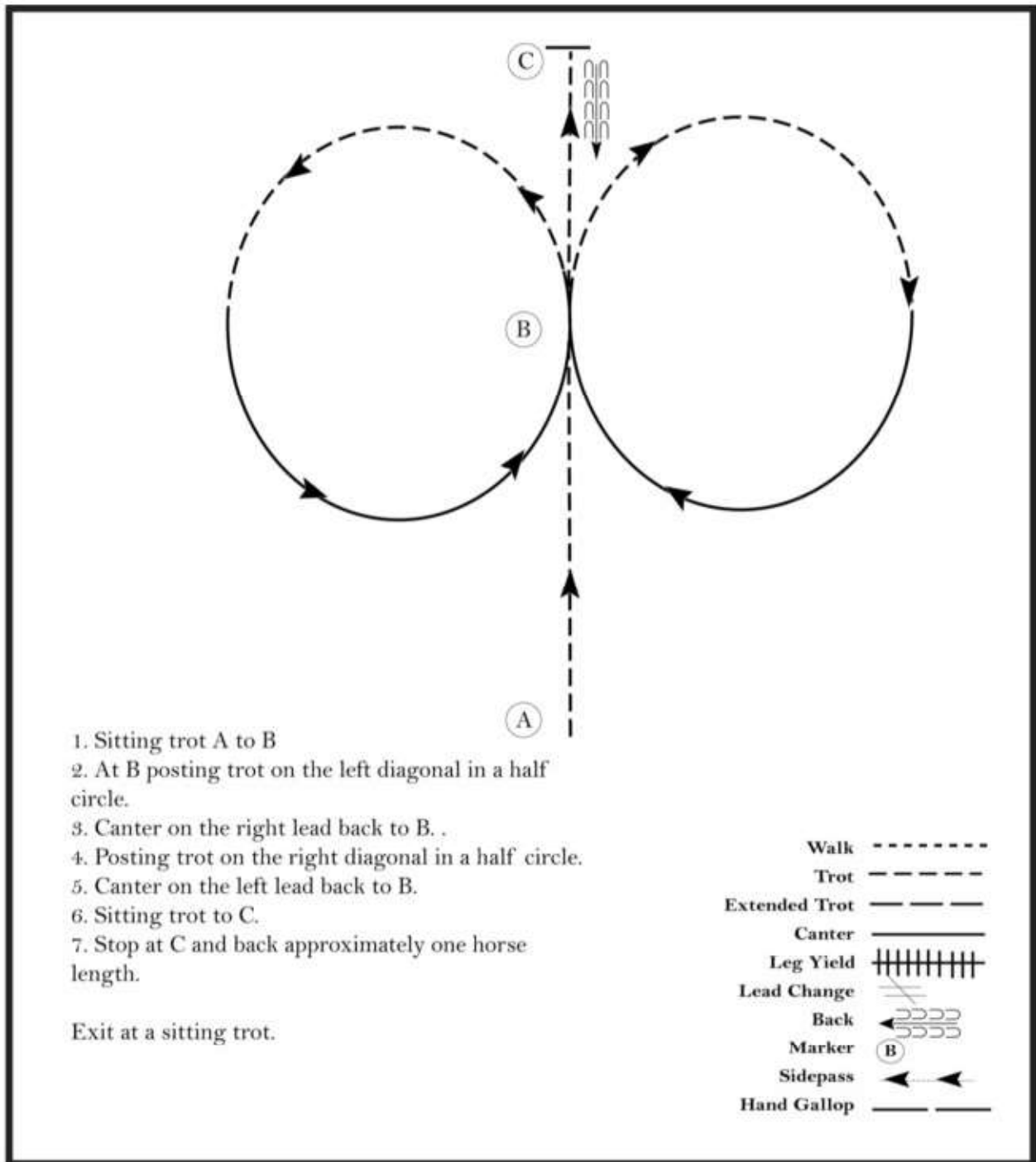

Pattern Provided by:

*Wyoming 4-H*

# Wyoming 4-H

## Wyoming 4-H Hunt Seat Equitation (Intermediate) -1

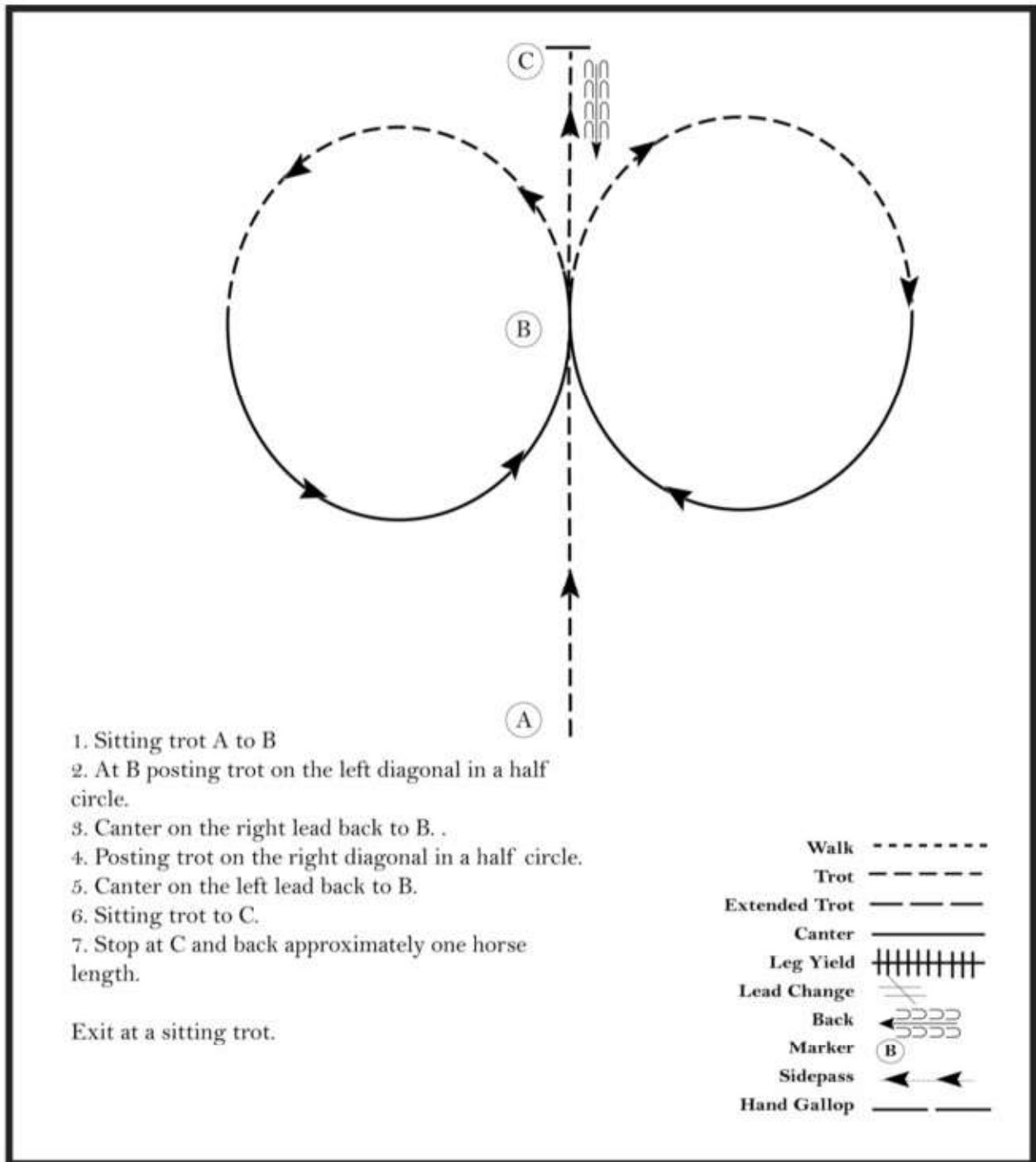

Pattern Provided by:

*Wyoming 4-H*

# Wyoming 4-H

## Wyoming 4-H Hunt Seat Equitation (Intermediate) -2

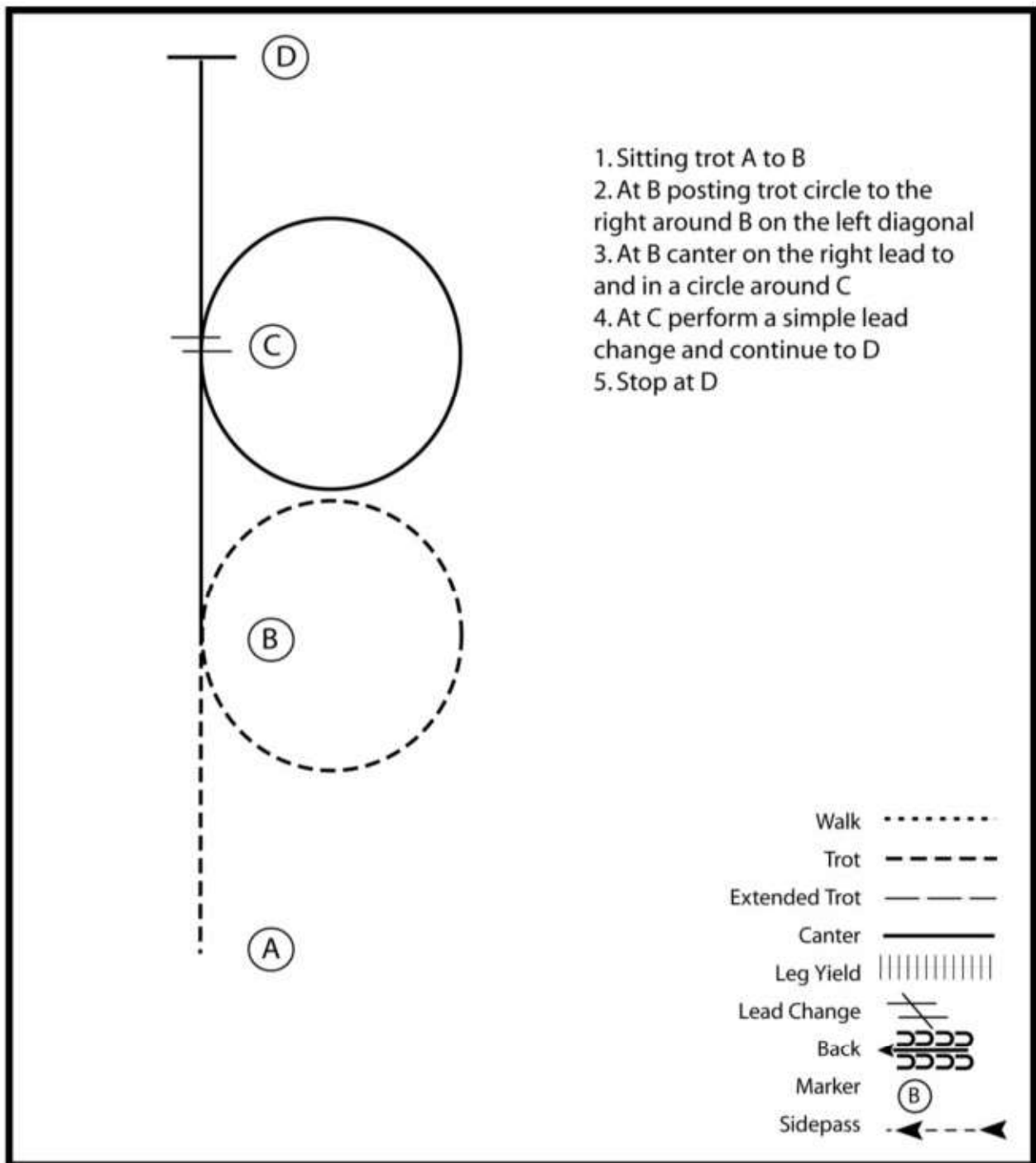

Pattern Provided by:

*Wyoming 4-H*

# Wyoming 4-H

## Wyoming 4-H Hunt Seat Equitation (Intermediate) -3

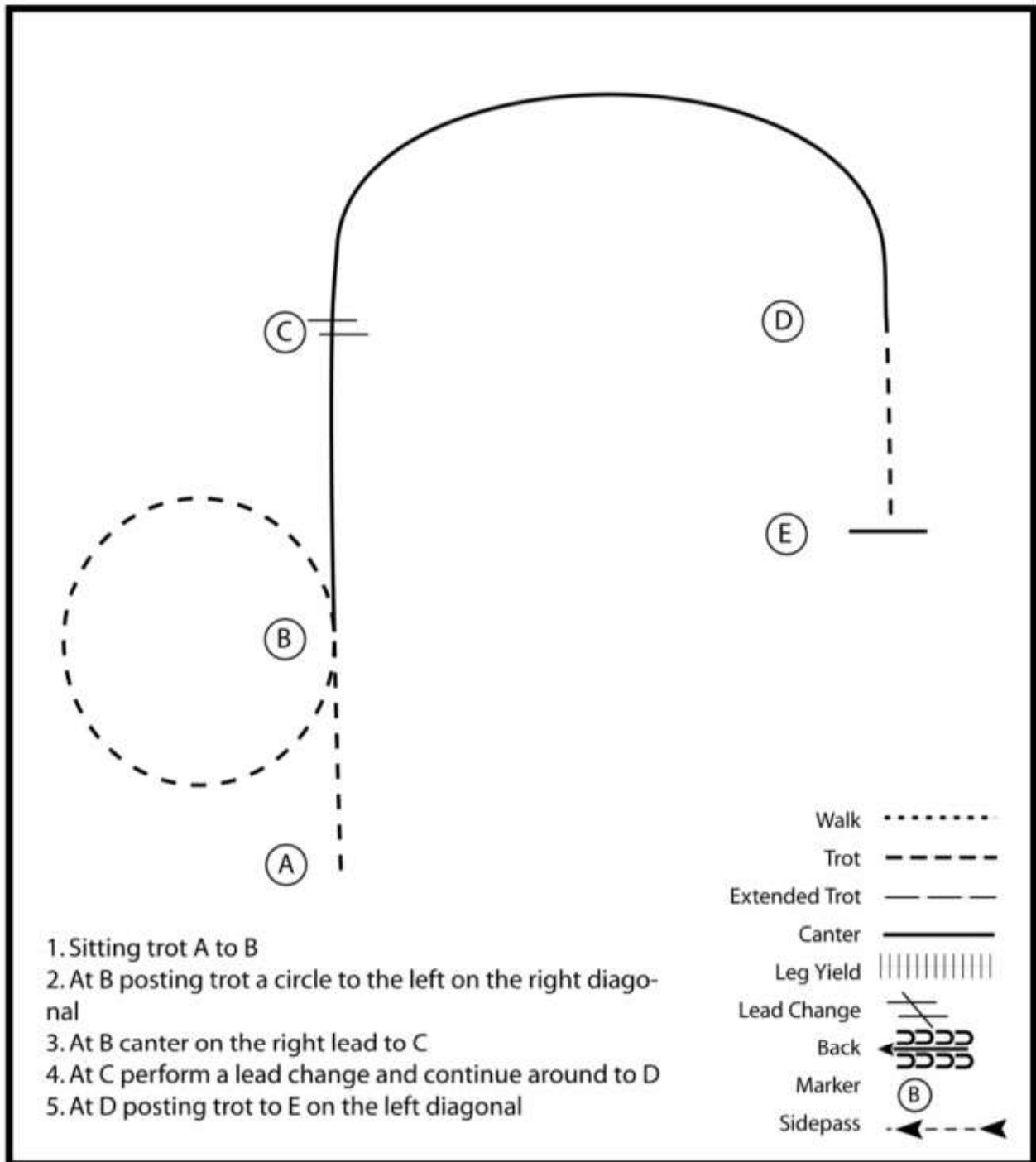

Pattern Provided by:

*Wyoming 4-H*

# Wyoming 4-H

## Wyoming 4-H Hunt Seat Equitation (Intermediate) -4

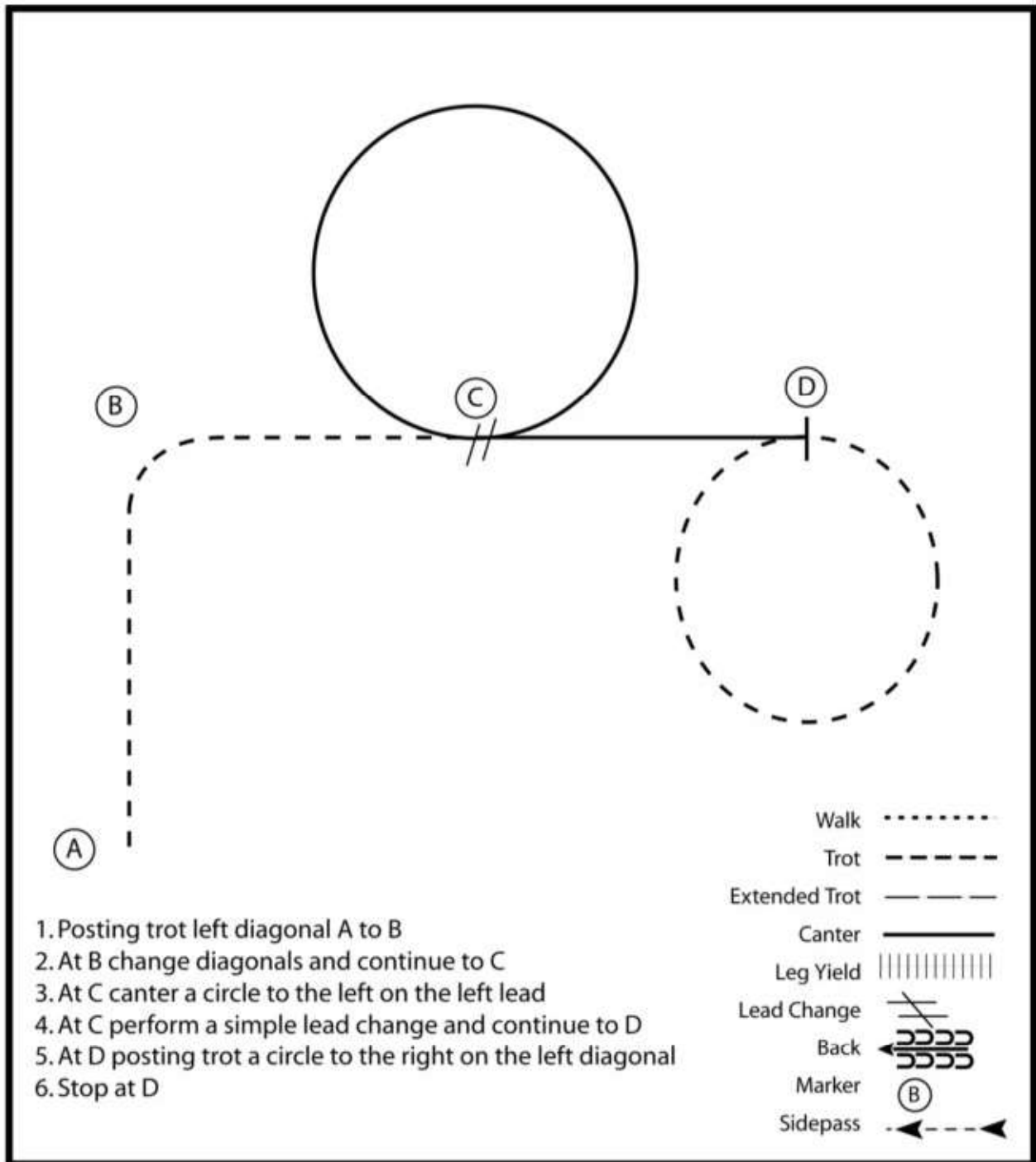

Pattern Provided by:

*Wyoming 4-H*

# Wyoming 4-H

## Wyoming 4-H Hunt Seat Equitation (Intermediate) -5

Be ready at A.

1. Posting trot on the left diagonal from A to B.
2. Stop at B and turn on the forehand 360 degrees to the right.
3. At B, canter on the right lead.
4. At the top of the arc, transition to the posting trot to D.
5. Stop and back approximately one horse length at D.

Exit at a sitting trot.

Walk	-----
Trot	- - - - -
Extended Trot	- - - - -
Canter	—————
Leg Yield	
Lead Change	///
Back	←←←←←
Marker	(B)
Sidepass	←←
Hand Gallop	-----

**Pattern Provided by:**

*Wyoming 4-H*

# Wyoming 4-H

## Wyoming 4-H Hunt Seat Equitation (Intermediate) -6

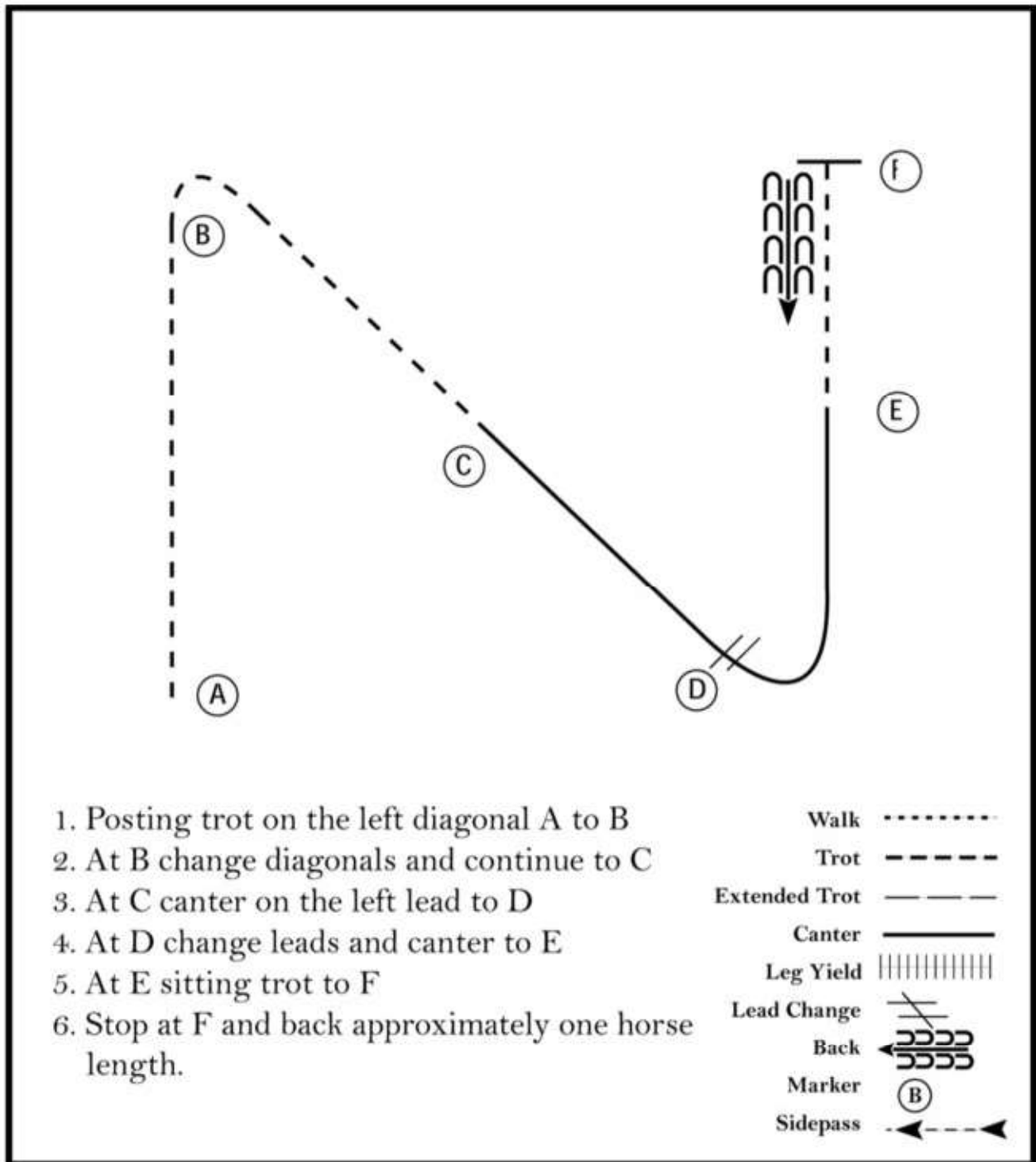

**Pattern Provided by:**

*Wyoming 4-H*

# Wyoming 4-H

## Wyoming 4-H Hunt Seat Equitation (Junior) -4

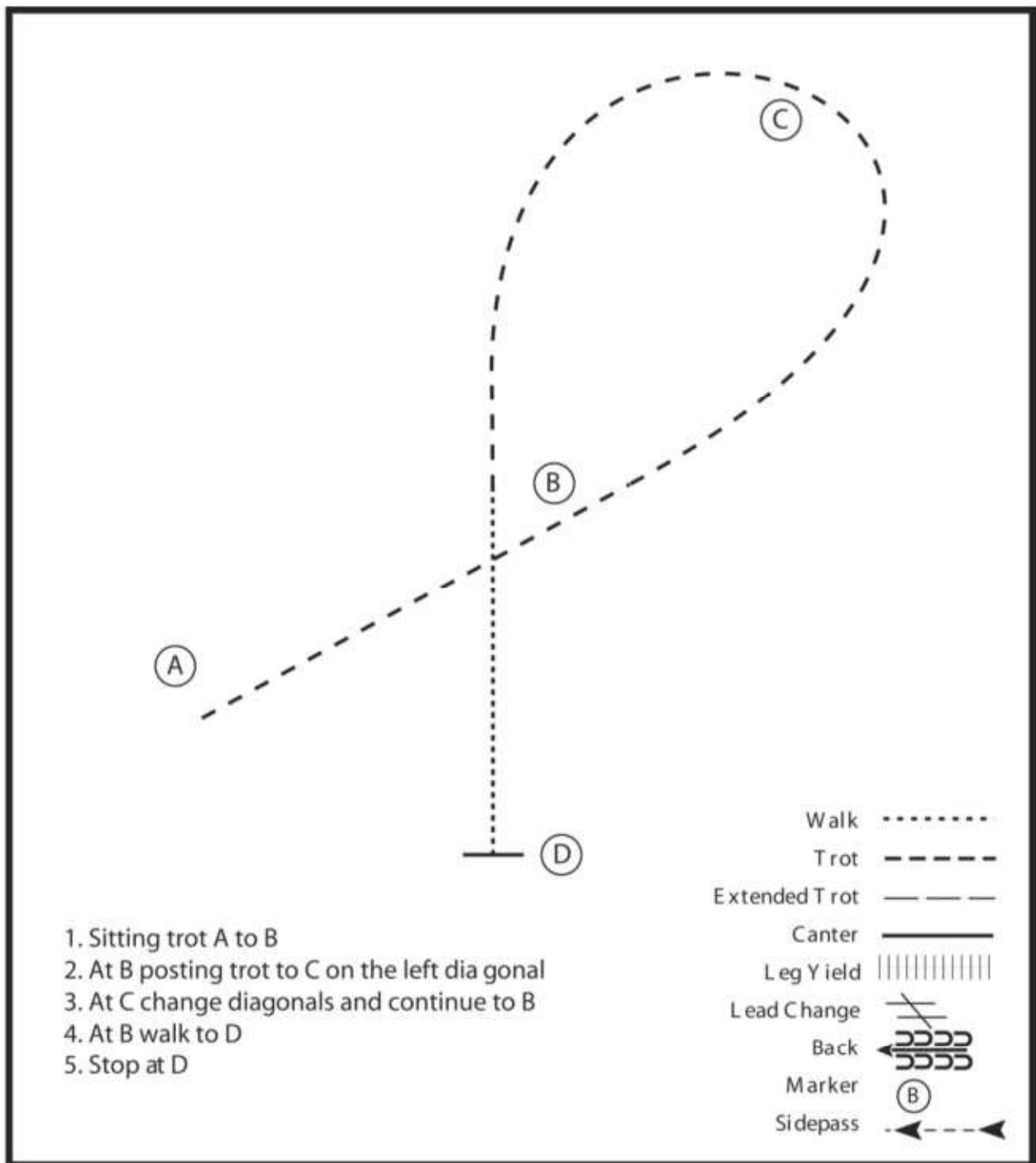

Pattern Provided by:

*Wyoming 4-H*

# Wyoming 4-H

## Wyoming 4-H Hunt Seat Equitation (Junior) -1

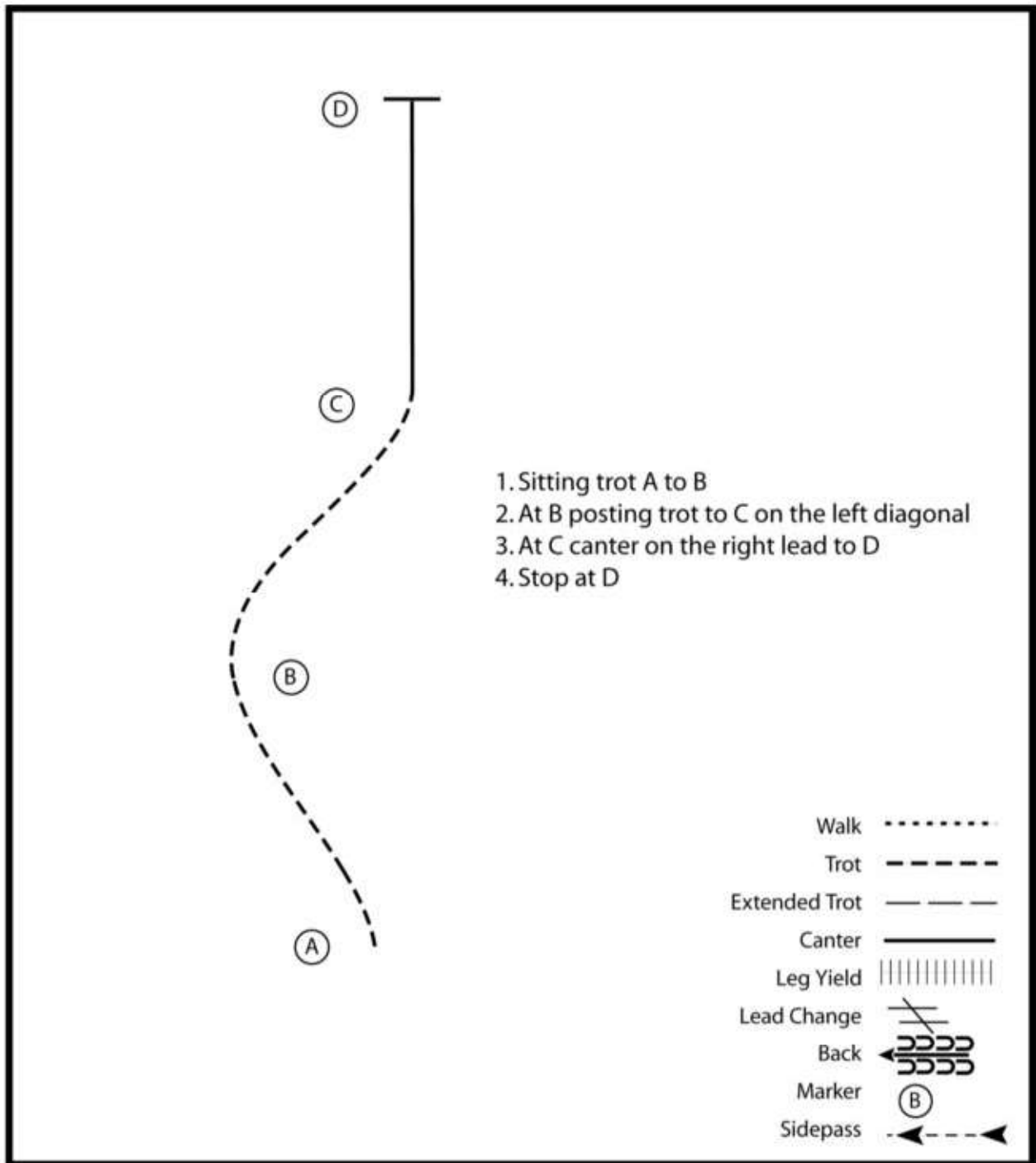

Pattern Provided by:

*Wyoming 4-H*

# Wyoming 4-H

## Wyoming 4-H Hunt Seat Equitation (Junior) -2

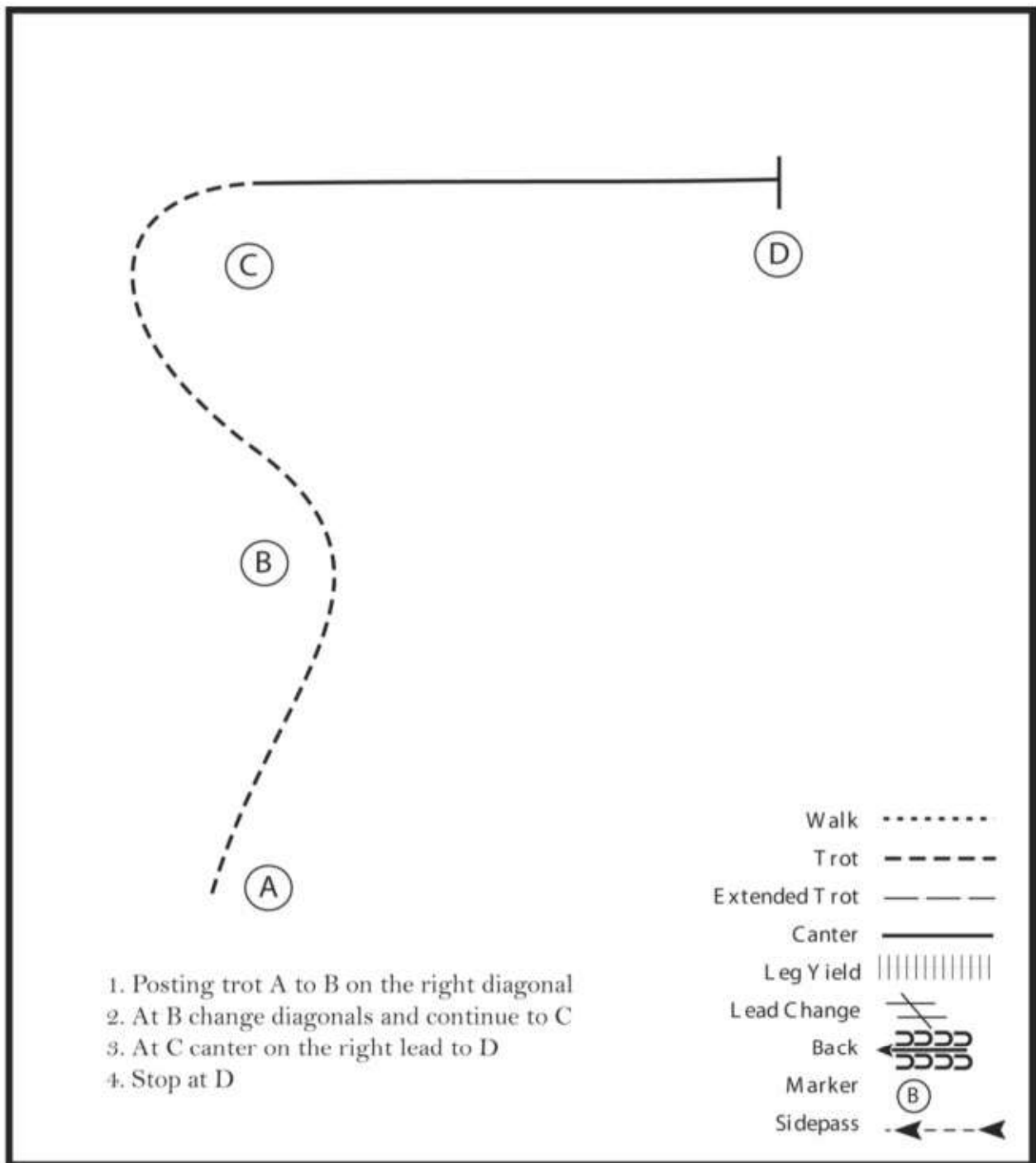

**Pattern Provided by:**

*Wyoming 4-H*

# Wyoming 4-H

## Wyoming 4-H Hunt Seat Equitation (Junior) -3

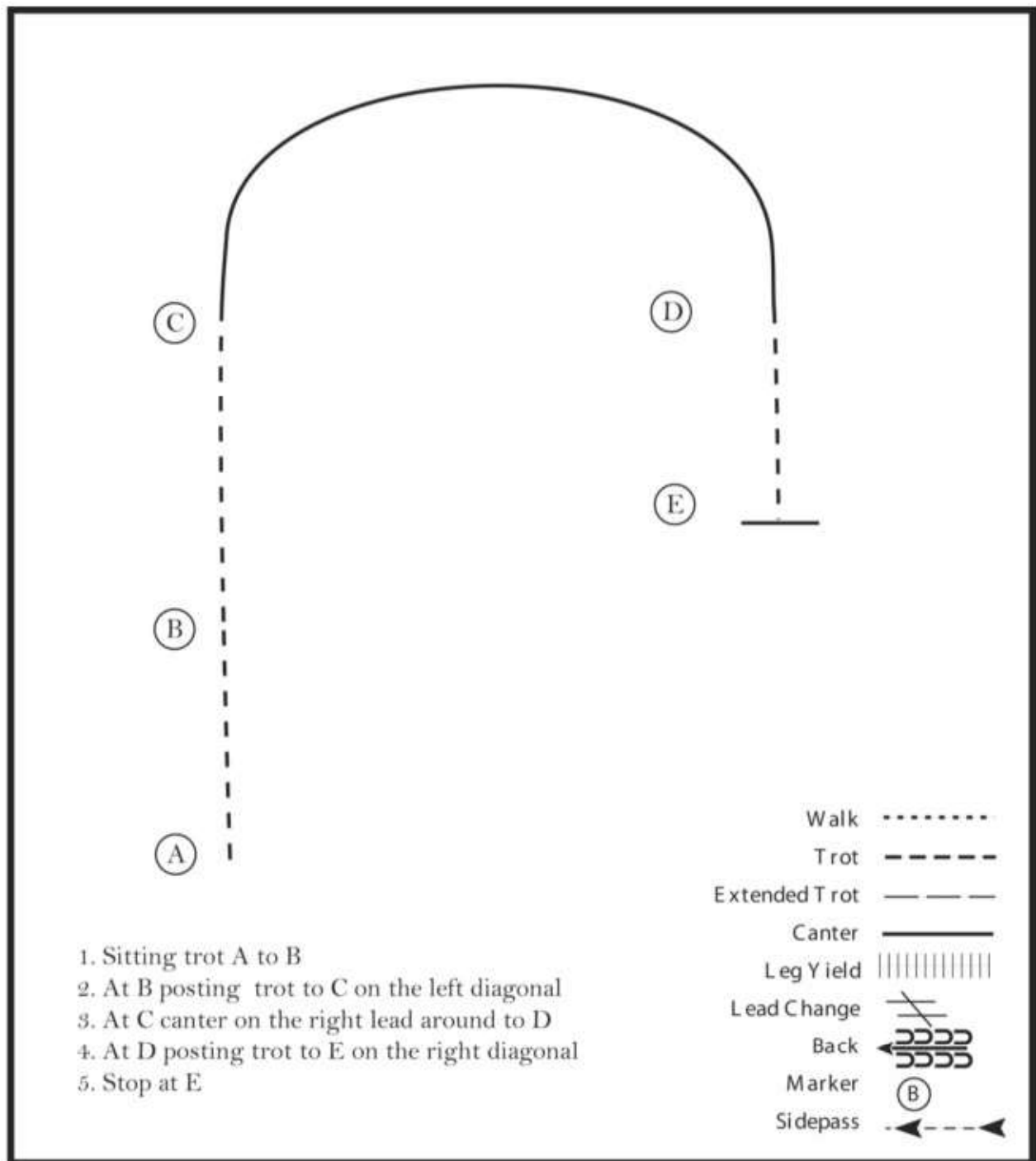

Pattern Provided by:

*Wyoming 4-H*



# Wyoming 4-H

## Wyoming 4-H Hunt Seat Equitation (Junior) -5

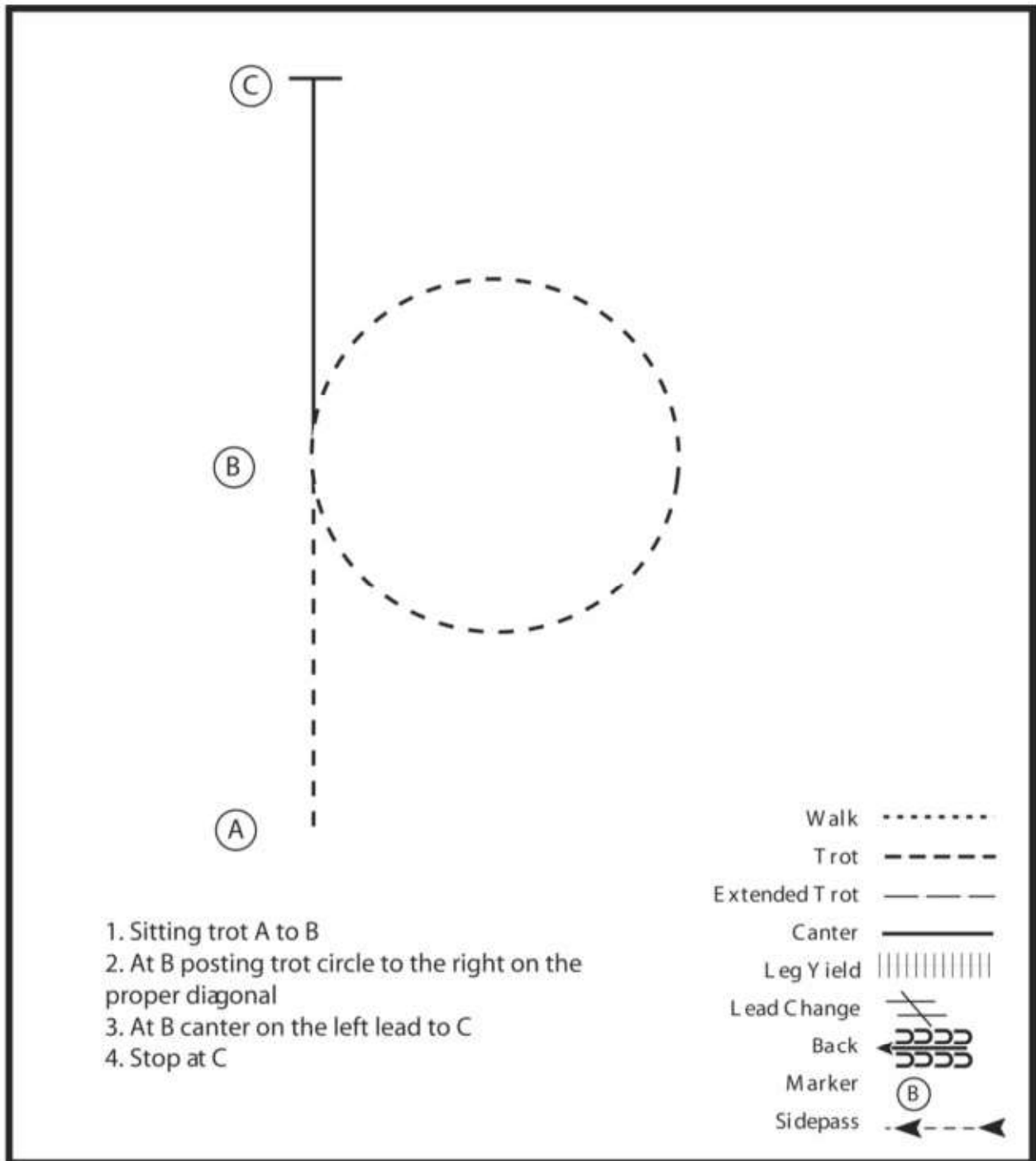

Pattern Provided by:

*Wyoming 4-H*

# Wyoming 4-H

## Wyoming 4-H Hunt Seat Equitation (Junior) -6

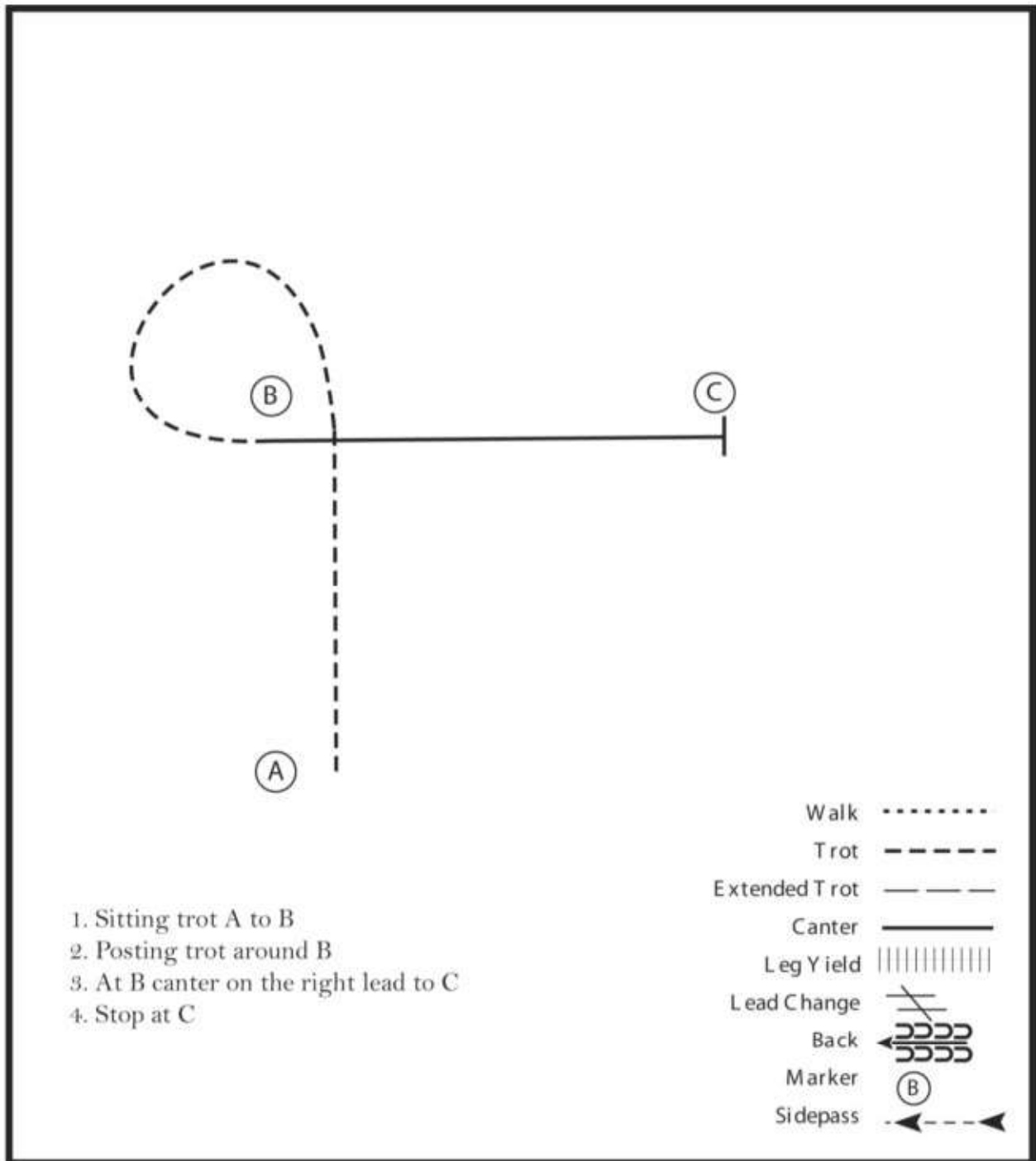

Pattern Provided by:

*Wyoming 4-H*

# Wyoming 4-H

## Wyoming 4-H Hunt Seat Equitation (Senior) - 1

Be ready before A.

1. Walk A to B.
2. Posting trot a circle to the left at B.
3. Canter on the left lead halfway to C.
4. Change leads halfway to C.
5. Canter on the right lead to C.
6. Posting trot a circle to the right at C.
7. Sitting trot from C to D.
8. Stop at D.
9. Perform a 180 degree turn to the right on the forehand.
10. Back approximately one horse length.

Follow the instructions of your ring steward.

Walk .....  
Trot - - - - -  
Extended Trot - - - - -  
Canter \_\_\_\_\_  
Leg Yield |||||  
Lead Change / \  
Back ← ← ← ← ←  
Marker (B)  
Sidepass ← ←  
Hand Gallop — —

**Pattern Provided by:**

*Wyoming 4-H*

# Wyoming 4-H

## Wyoming 4-H Hunt Seat Equitation (Senior) - 2

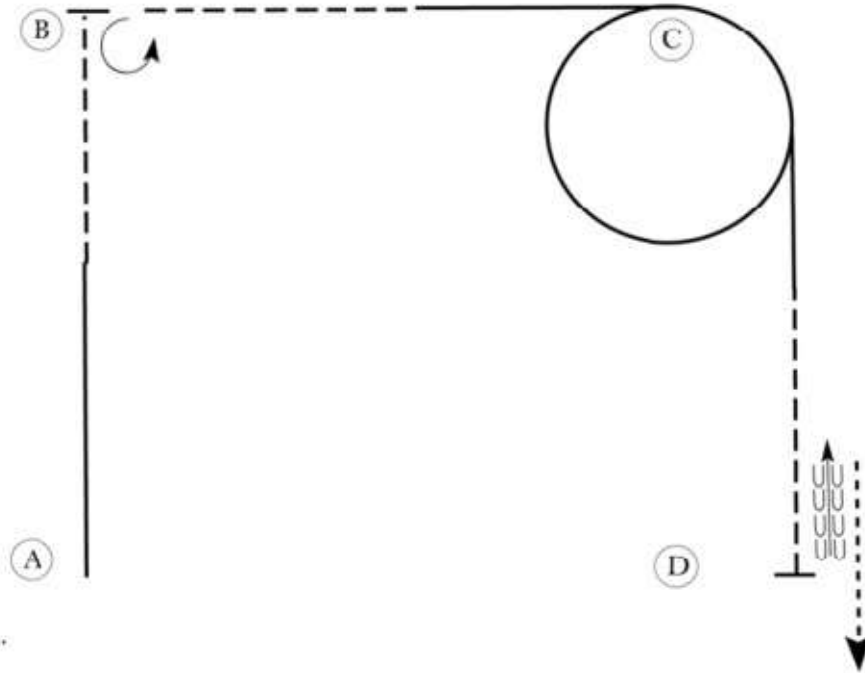

Be ready at A.

1. Canter on the left lead halfway to B.
2. Sitting trot to B.
3. Stop at B and execute a 270 degree turn on the haunches to the left.
4. Posting trot on the right diagonal halfway to C.
5. Canter on the right lead to and in a circle around C.
6. Continue on the right lead halfway to D.
7. Posting trot on the left diagonal to D.
8. Stop at D and back approximately one horse length.
9. Walk forward to and past D.

Walk	-----
Trot	-----
Extended Trot	-----
Canter	-----
Leg Yield	
Lead Change	↘
Back	←←←←
Marker	⊙ B
Sidepass	←←
Hand Gallop	-----

Follow the instructions of your ring steward.

**Pattern Provided by:**

*Wyoming 4-H*

# Wyoming 4-H

## Wyoming 4-H Hunt Seat Equitation (Senior) – 3

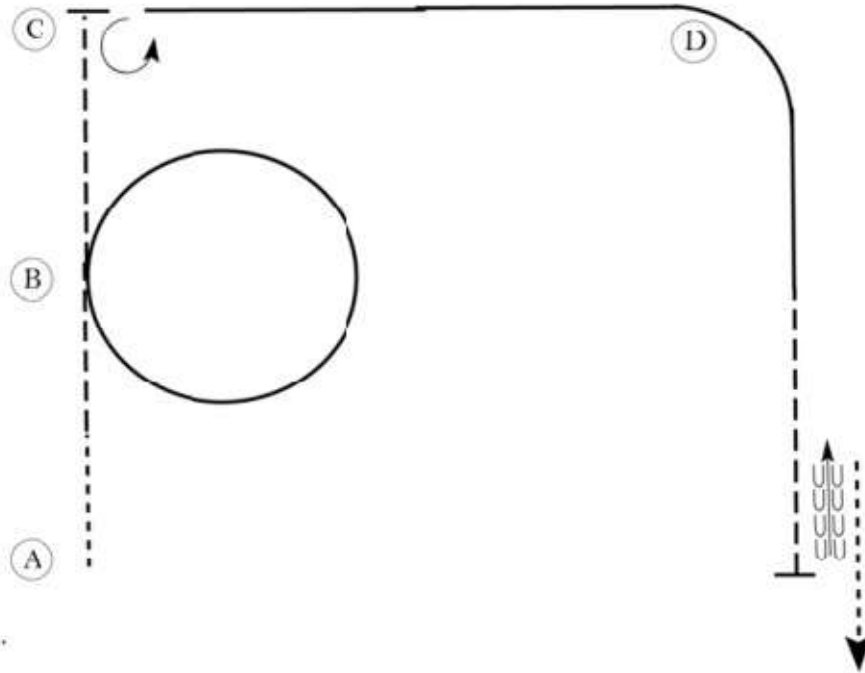

Be ready at A.

1. Walk two horse lengths from A.
2. Sitting trot to B.
3. Canter a circle to the right at B.
4. Posting trot on the left diagonal to C.
5. Stop at C and perform a 270 degree turn on the forehand to the left.
6. Canter on the left lead to and around D.
7. When even with B, begin a posting trot on the right diagonal.
8. Stop when even with A and back approximately one horse length.

Walk away from D and follow the instructions of your ring steward.

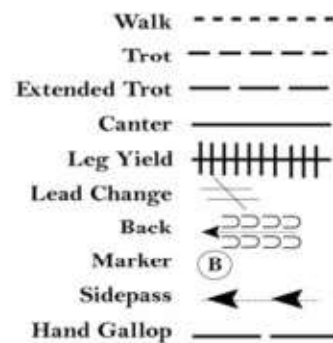

**Pattern Provided by:**

*Wyoming 4-H*

# Wyoming 4-H

## Wyoming 4-H Hunt Seat Equitation (Senior) – 4

Be ready at A.

1. Posting trot to center of pattern.
2. Break to a walk and walk a small half circle.
3. Stop and back a square corner.
4. Perform a 1/4 turn on the forehand left.
5. Canter on the right lead to B.
6. Posting trot on the left diagonal to center of pattern.
7. Left lead canter in a half circle and to exit.

Follow the instructions of your ring steward.

Walk	-----
Trot	- - - - -
Extended Trot	- - - - -
Canter	—————
Leg Yield	
Lead Change	///
Back	←←←←←
Marker	ⓑ
Sidepass	←←
Hand Gallop	- - - - -

**Pattern Provided by:**

*Wyoming 4-H*

# Wyoming 4-H

## Wyoming 4-H Hunt Seat Equitation (Senior) – 5

Be ready at A.

1. Walk approximately 2 horse lengths.
2. Posting trot on the left diagonal to B and in a half circle until even with B.
3. Canter on the right lead until even with A.
4. Hand gallop a half circle to A.
5. Posting trot on the right diagonal to B.
6. Left lead canter in a half circle until even with B.
7. Halt and back approximately one horse length.
8. Ext t pattern at a sitting trot.

Follow the instructions of your ring steward.

Walk	-----
Trot	- - - - -
Extended Trot	-----
Canter	-----
Leg Yield	
Lead Change	↘
Back	←←←←
Marker	(B)
Sidepass	←←
Hand Gallop	-----

**Pattern Provided by:**

*Wyoming 4-H*

# Wyoming 4-H

## Wyoming 4-H Hunt Seat Equitation (Senior) – 6

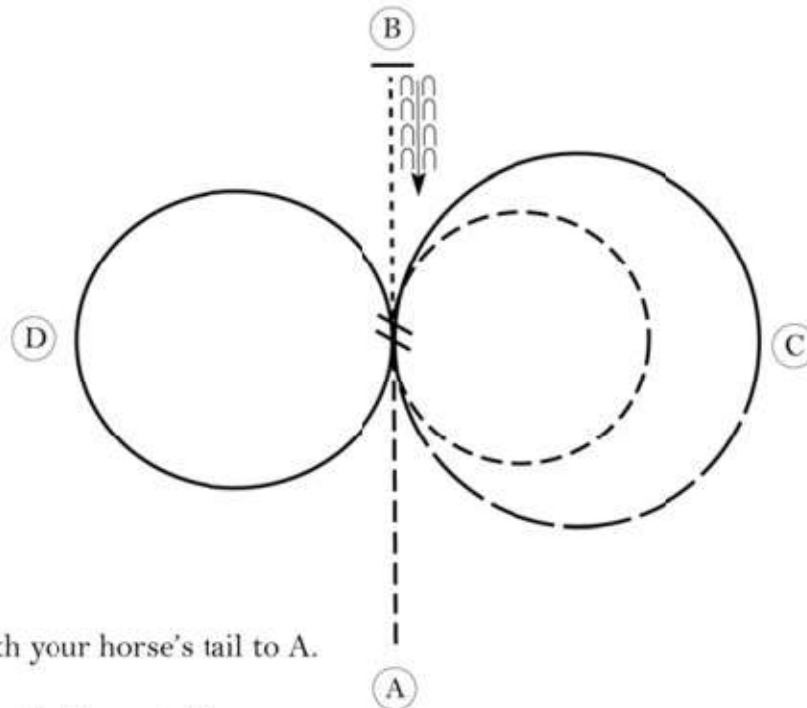

Be ready with your horse's tail to A.

1. Sitting trot halfway to B.
2. Rising trot circle to right.
3. Canter a half circle to the right.
4. Hand gallop and close the circle.
5. Perform a simple lead change at the center of the pattern.
6. Canter a circle to the left.
7. Working walk from the center to B.
8. Stop in front of B and back approximately one horse length.

Follow the directions of your ring steward.

Walk	-----
Trot	- - - - -
Extended Trot	— — — — —
Canter	—————
Lead Change	
Back	
Marker	
Hand Gallop	— — — — —

**Pattern Provided by:**

*Wyoming 4-H*

# Wyoming 4-H

## Wyoming 4-H Hunt Seat Equitation (Senior) – 5

Be ready at A.

1. Walk approximately 2 horse lengths.
2. Posting trot on the left diagonal to B and in a half circle until even with B.
3. Canter on the right lead until even with A.
4. Hand gallop a half circle to A.
5. Posting trot on the right diagonal to B.
6. Left lead canter in a half circle until even with B.
7. Halt and back approximately one horse length.
8. Exit pattern at a sitting trot.

Follow the instructions of your ring steward.

Walk	-----
Trot	- - - - -
Extended Trot	-----
Canter	-----
Leg Yield	
Lead Change	///
Back	←○○○○
Marker	⊙
Sidepass	←←
Hand Gallop	-----

**Pattern Provided by:**

*Wyoming 4-H*

# Wyoming 4-H

## Hunter Hack (Intermediate)-1

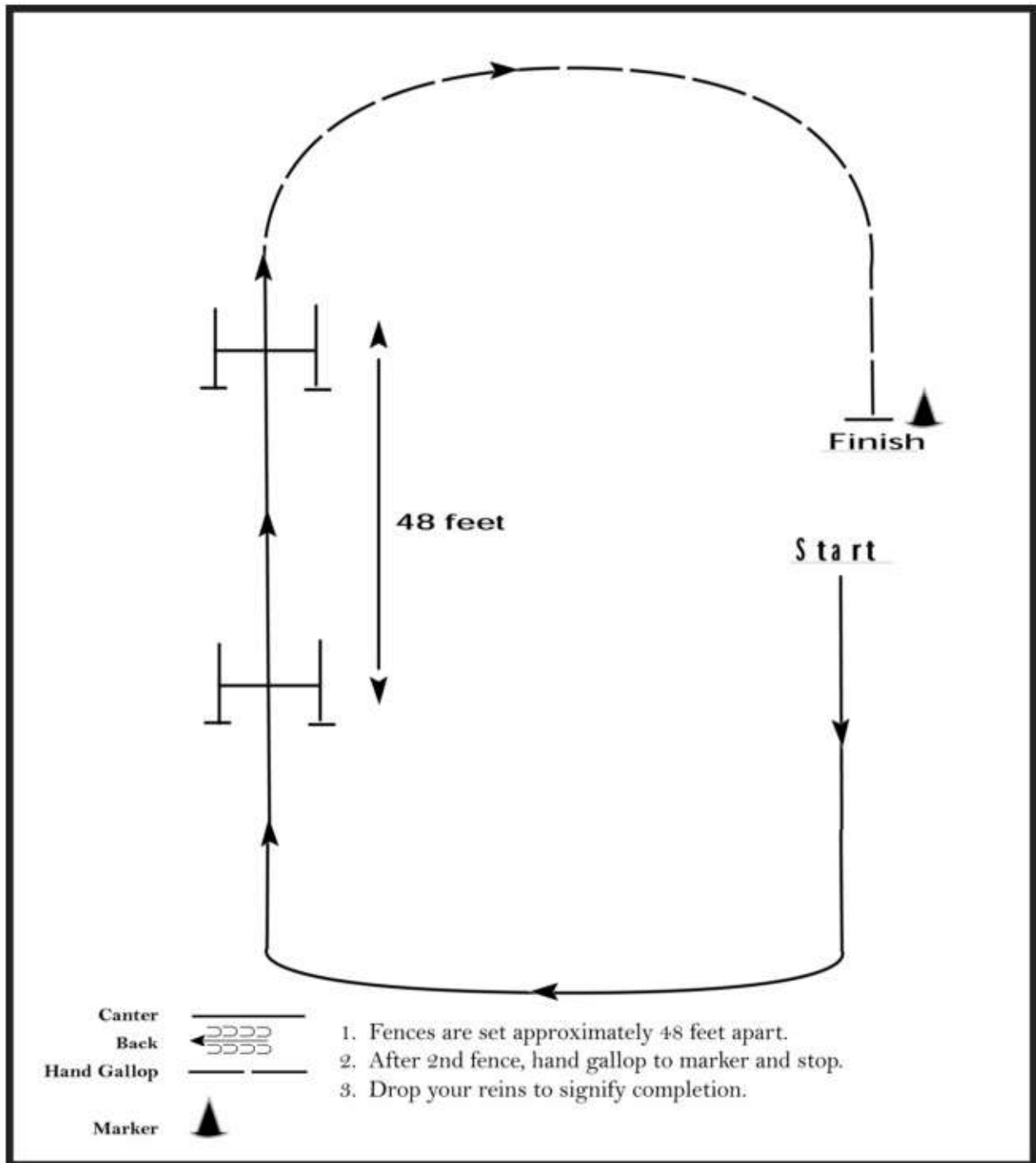

**Pattern Provided by:**

*Wyoming 4-H*

# Wyoming 4-H

## Hunter Hack (Intermediate) -2

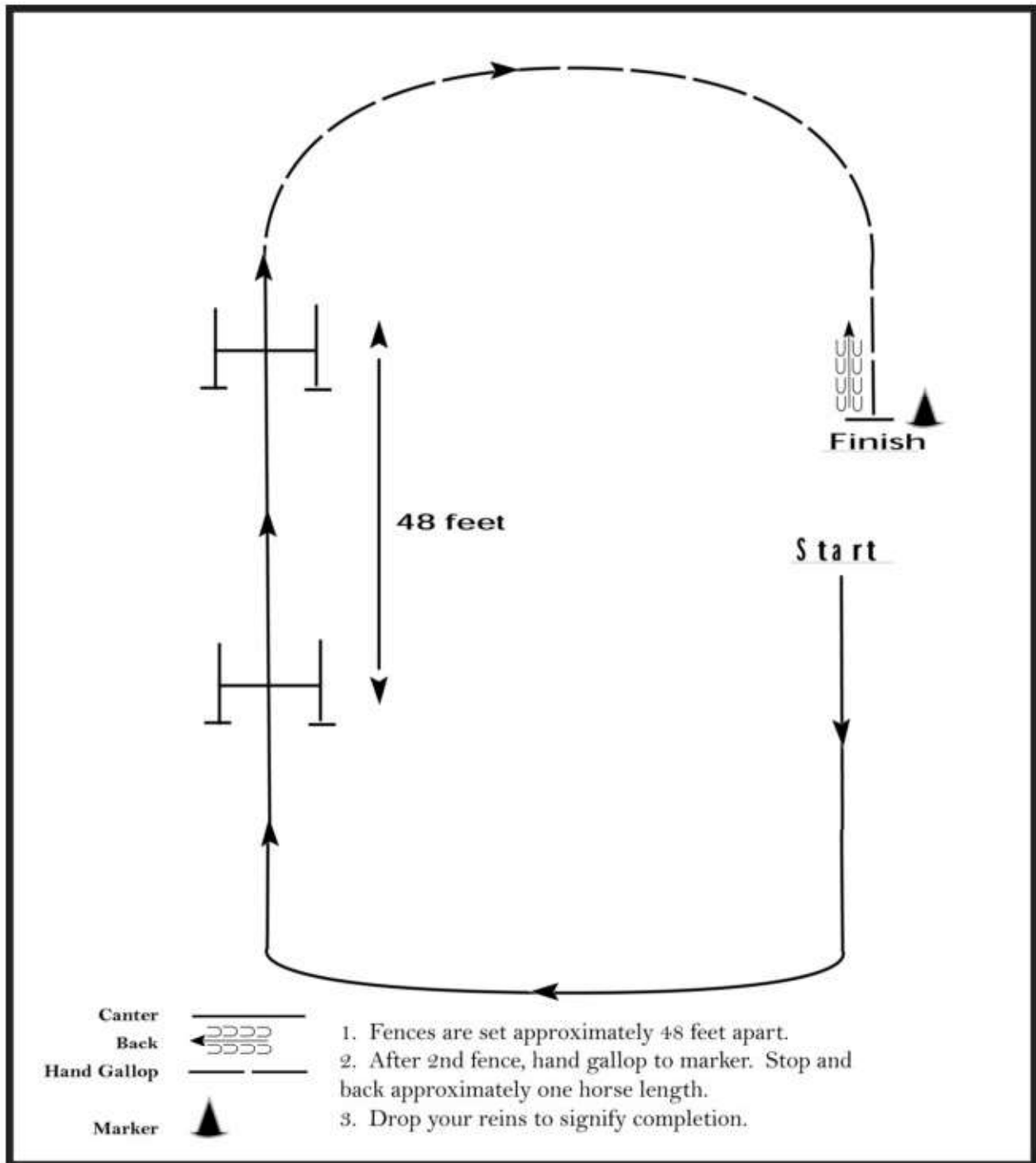

**Pattern Provided by:**

*Wyoming 4-H*

# Wyoming 4-H

## Hunter Hack (intermediate)- 3

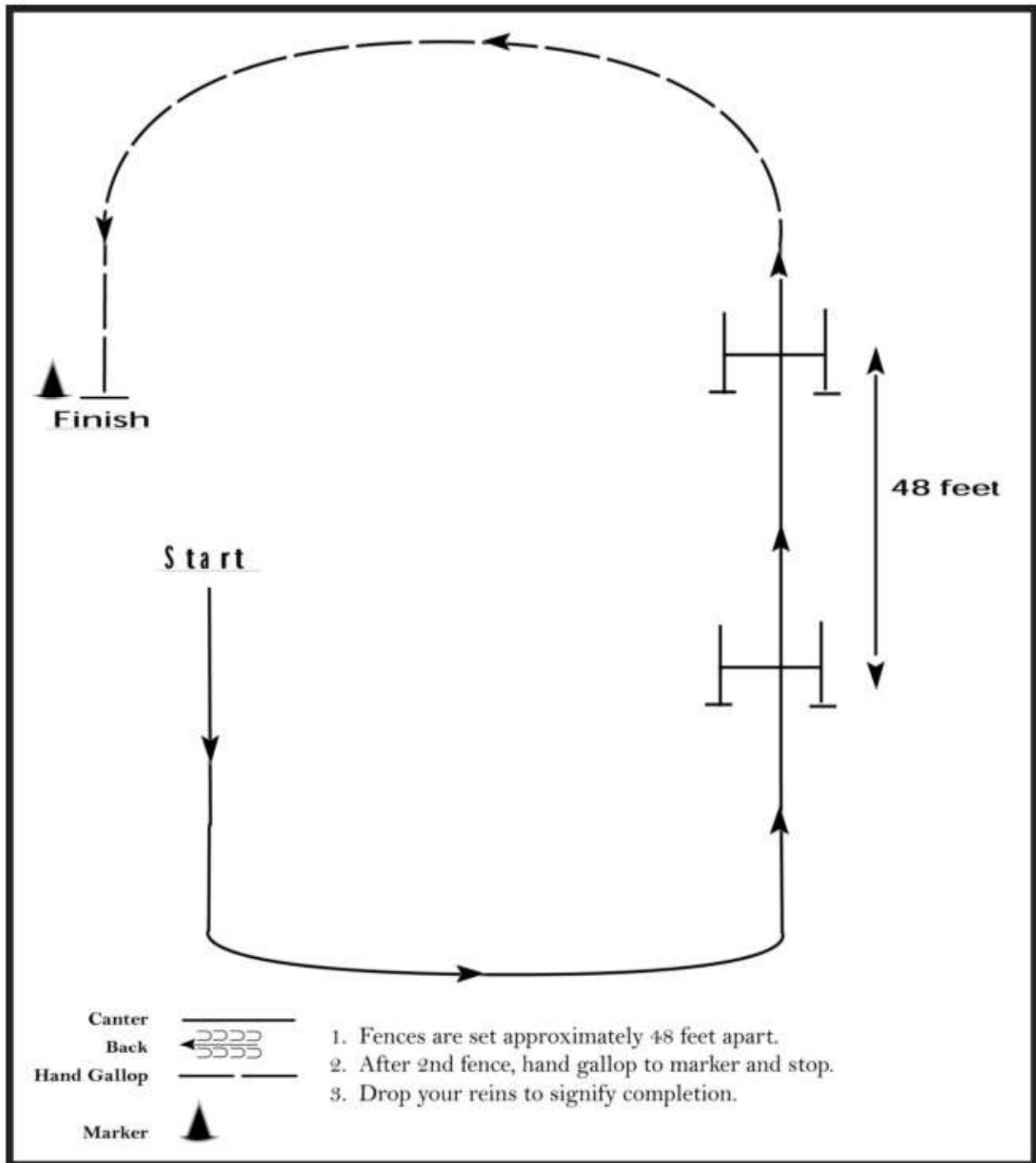

**Pattern Provided by:**

*Wyoming 4-H*



# Wyoming 4-H

## Hunter Hack (Junior) -1

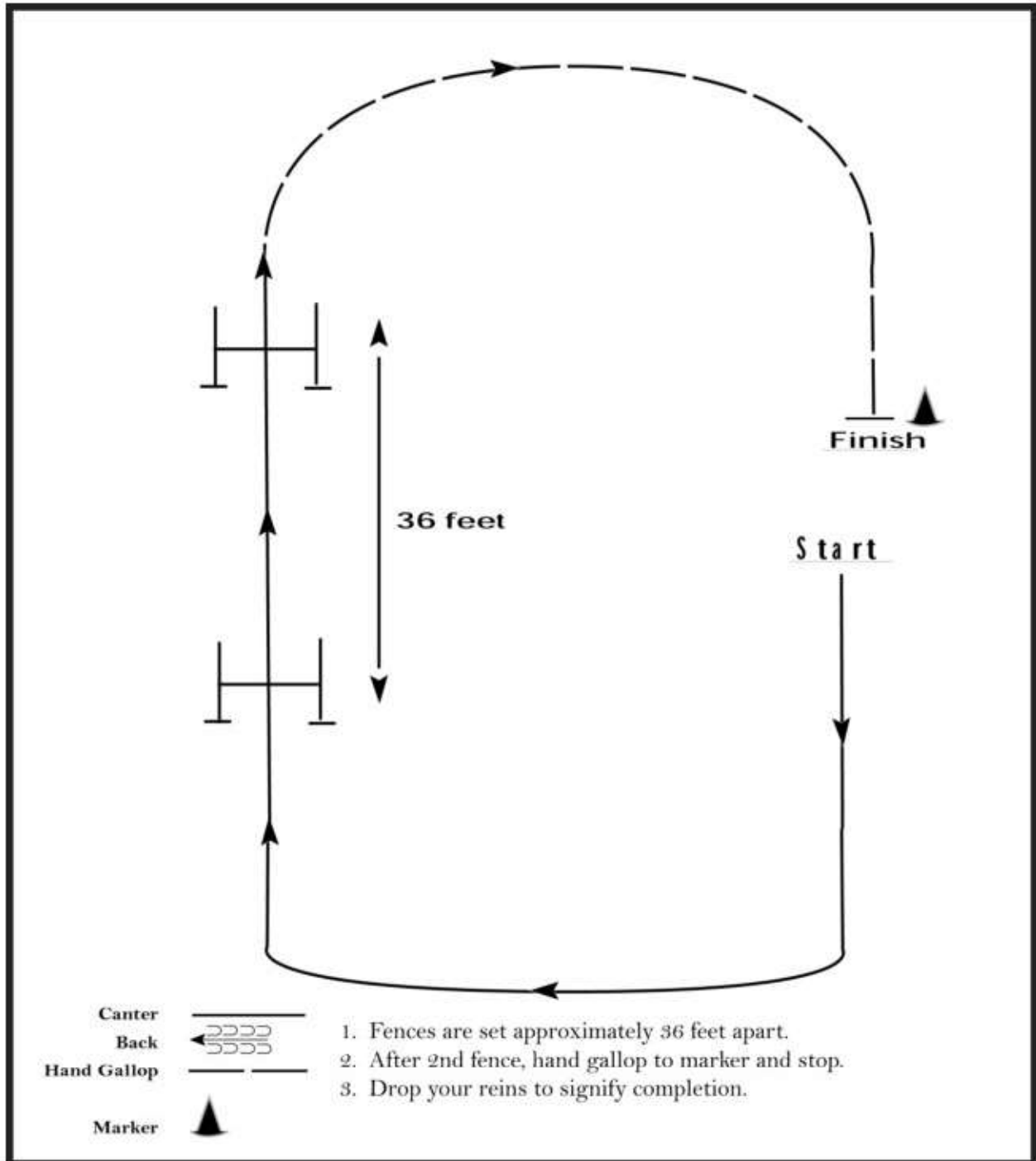

**Pattern Provided by:**

*Wyoming 4-H*

# Wyoming 4-H

## Hunter Hack (Junior) -2

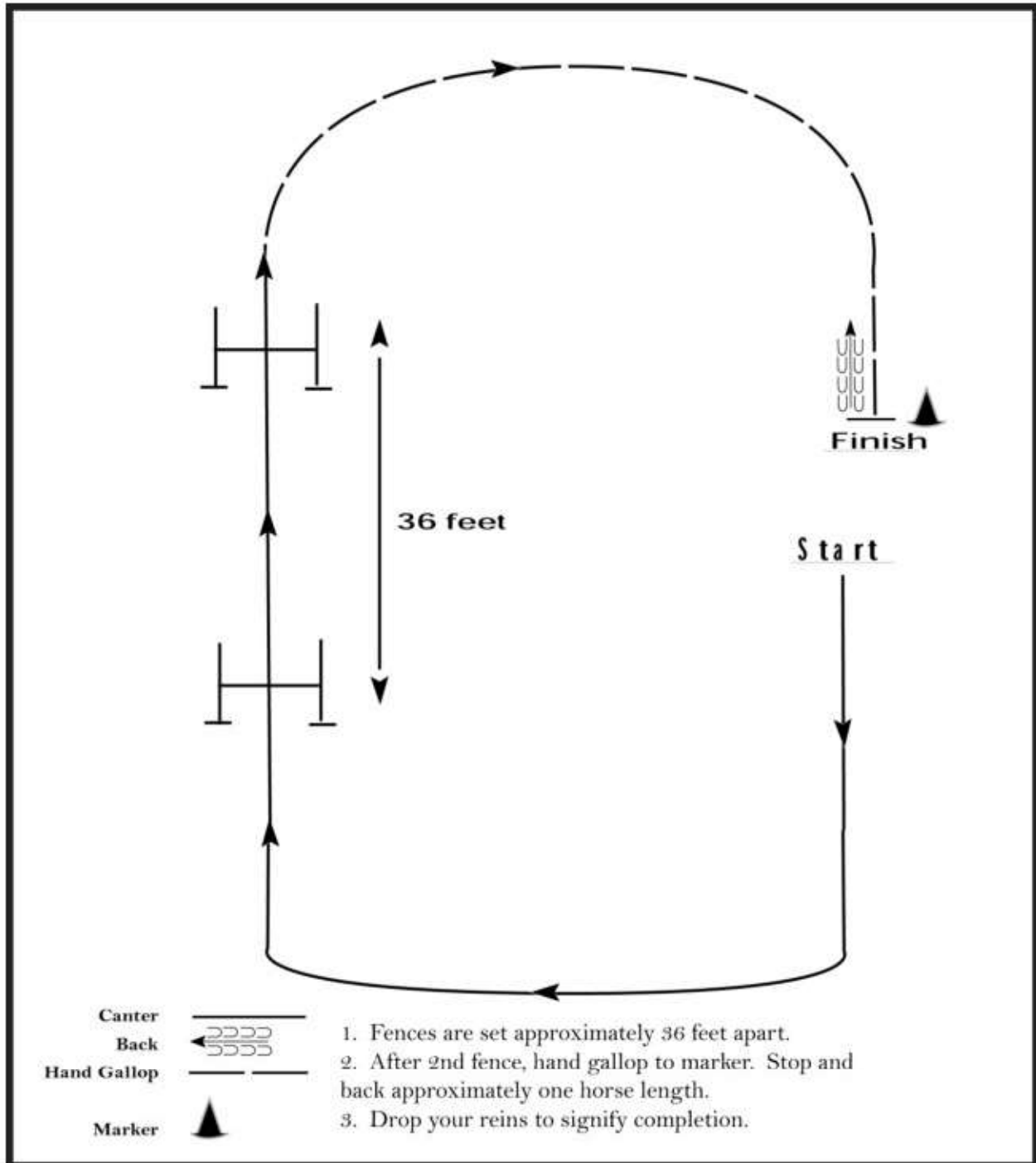

**Pattern Provided by:**

*Wyoming 4-H*

# Wyoming 4-H

## Hunter Hack (Junior) -3

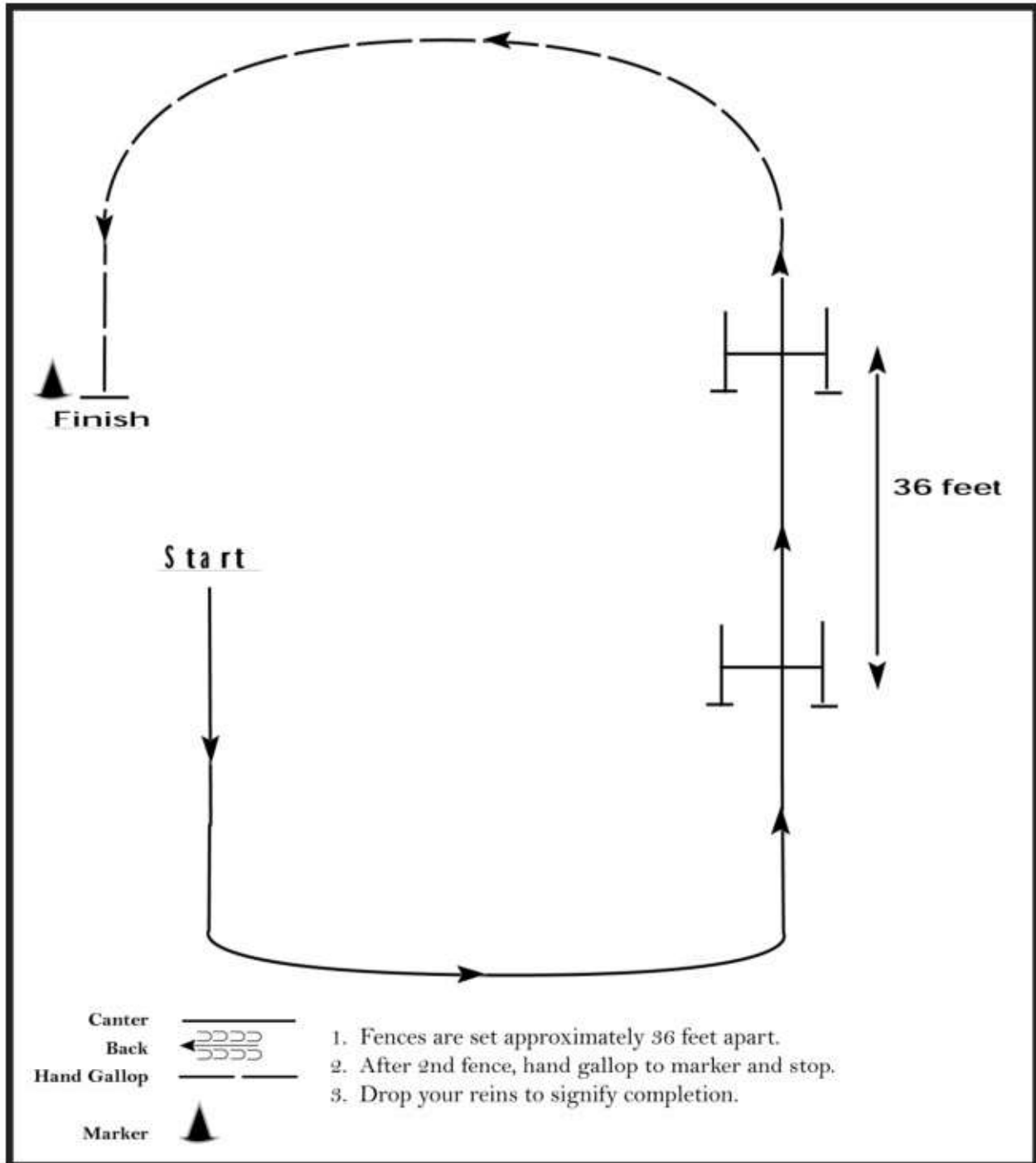

**Pattern Provided by:**

*Wyoming 4-H*

# Wyoming 4-H

## Hunter Hack (Junior) -4

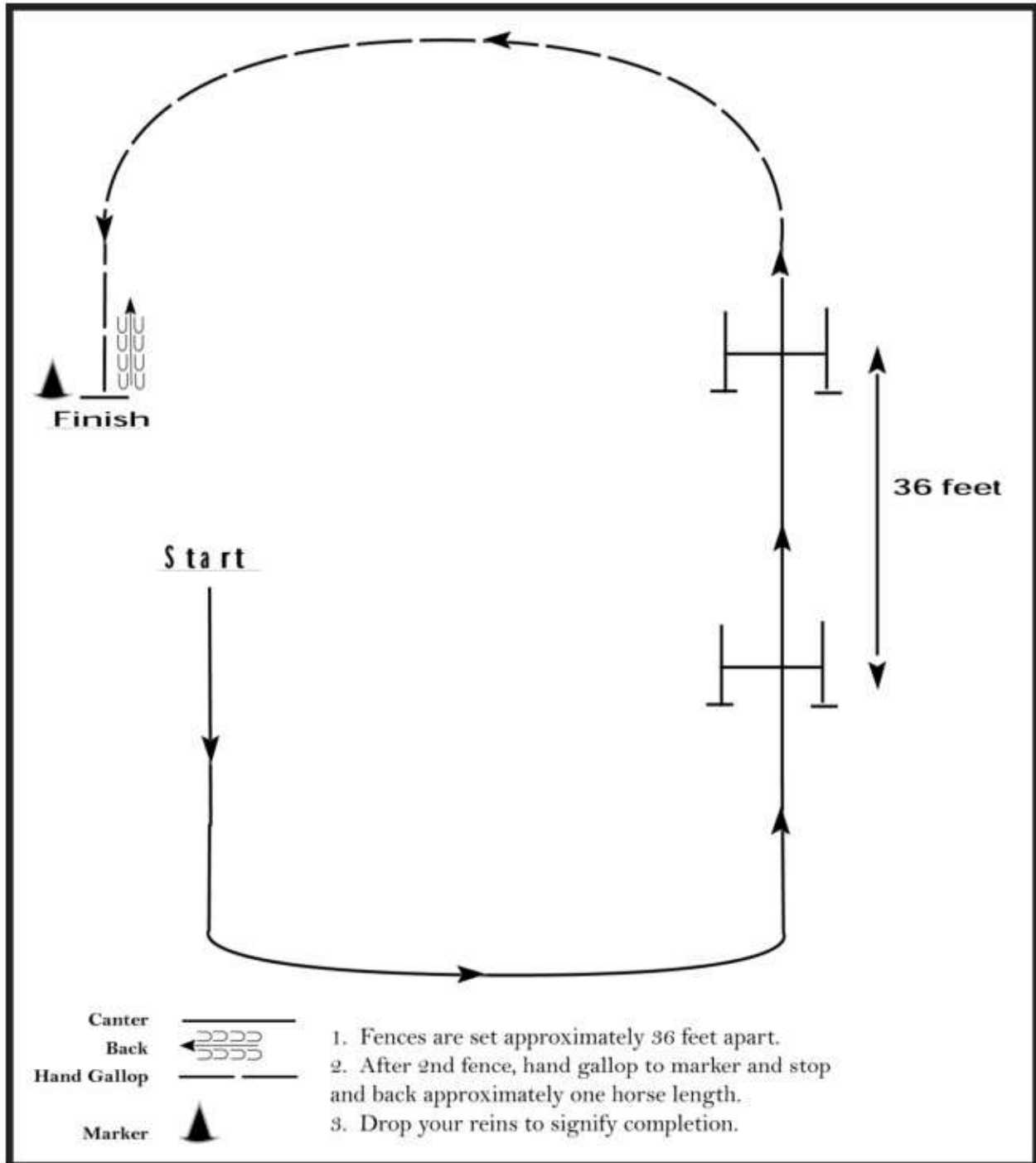

**Pattern Provided by:**

*Wyoming 4-H*

# Wyoming 4-H

## Hunter Hack (Senior) -1

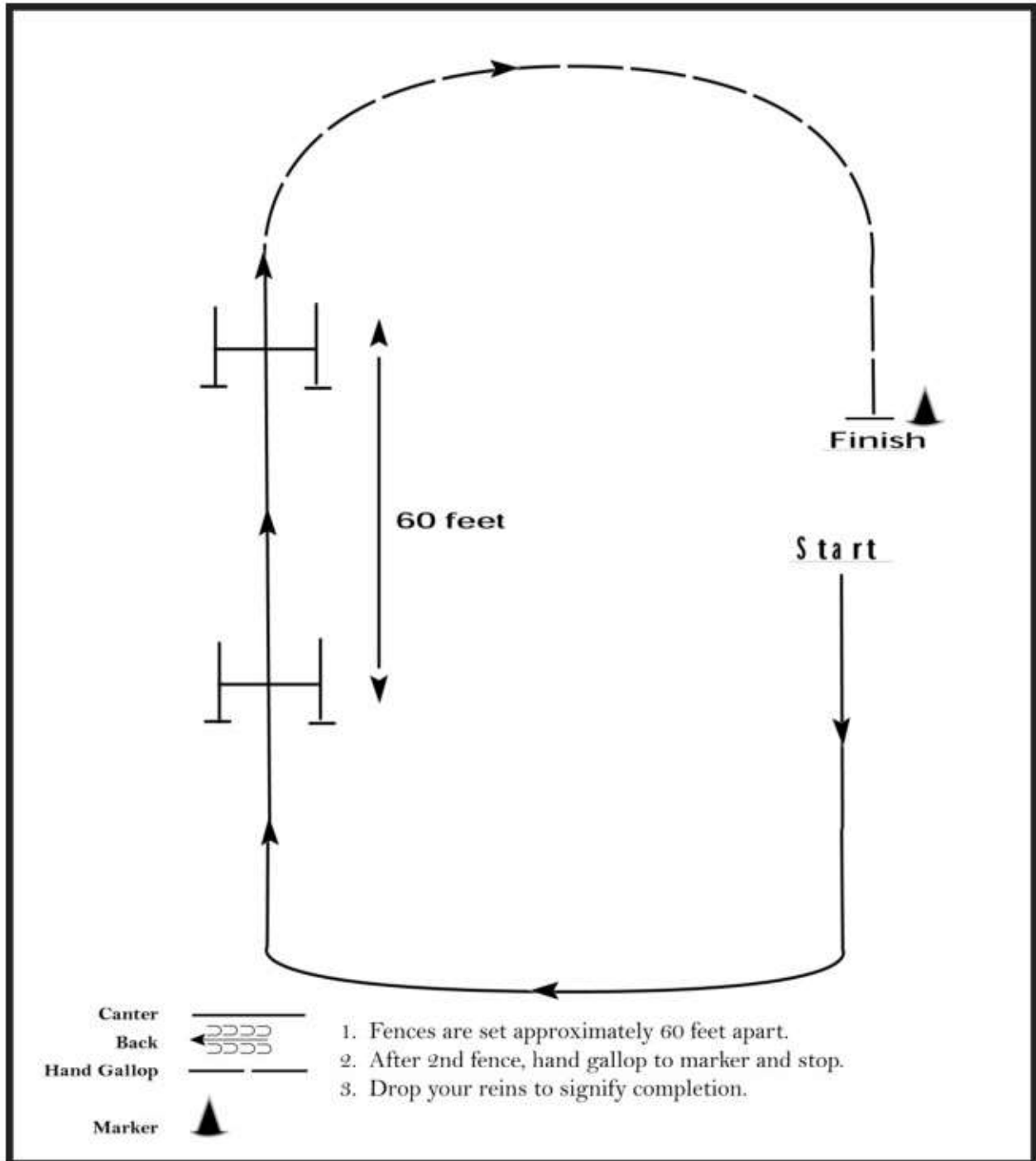

**Pattern Provided by:**

*Wyoming 4-H*

# Wyoming 4-H

## Hunter Hack (Senior) -2

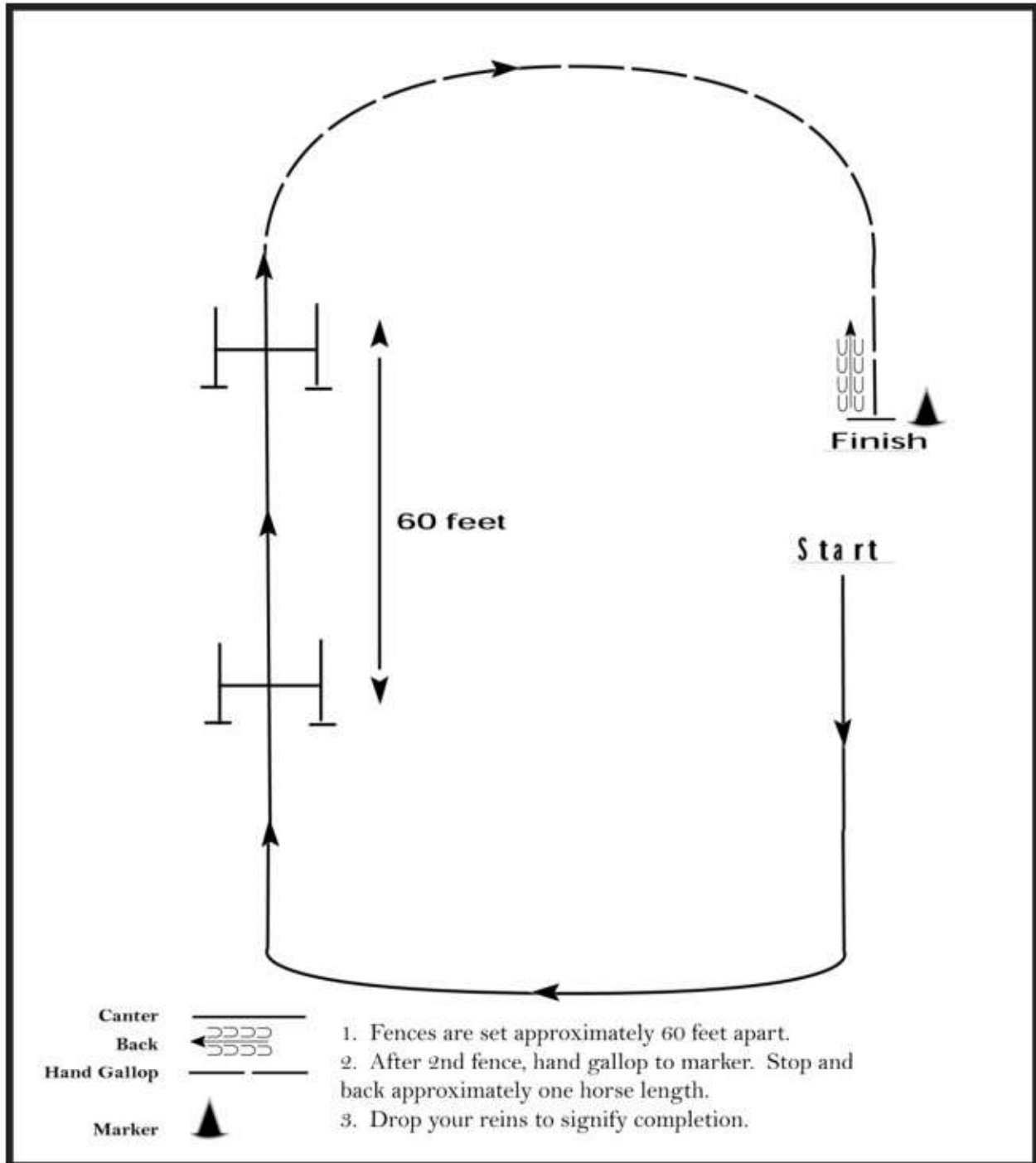

**Pattern Provided by:**

*Wyoming 4-H*

# Wyoming 4-H

## Hunter Hack (Senior) -3

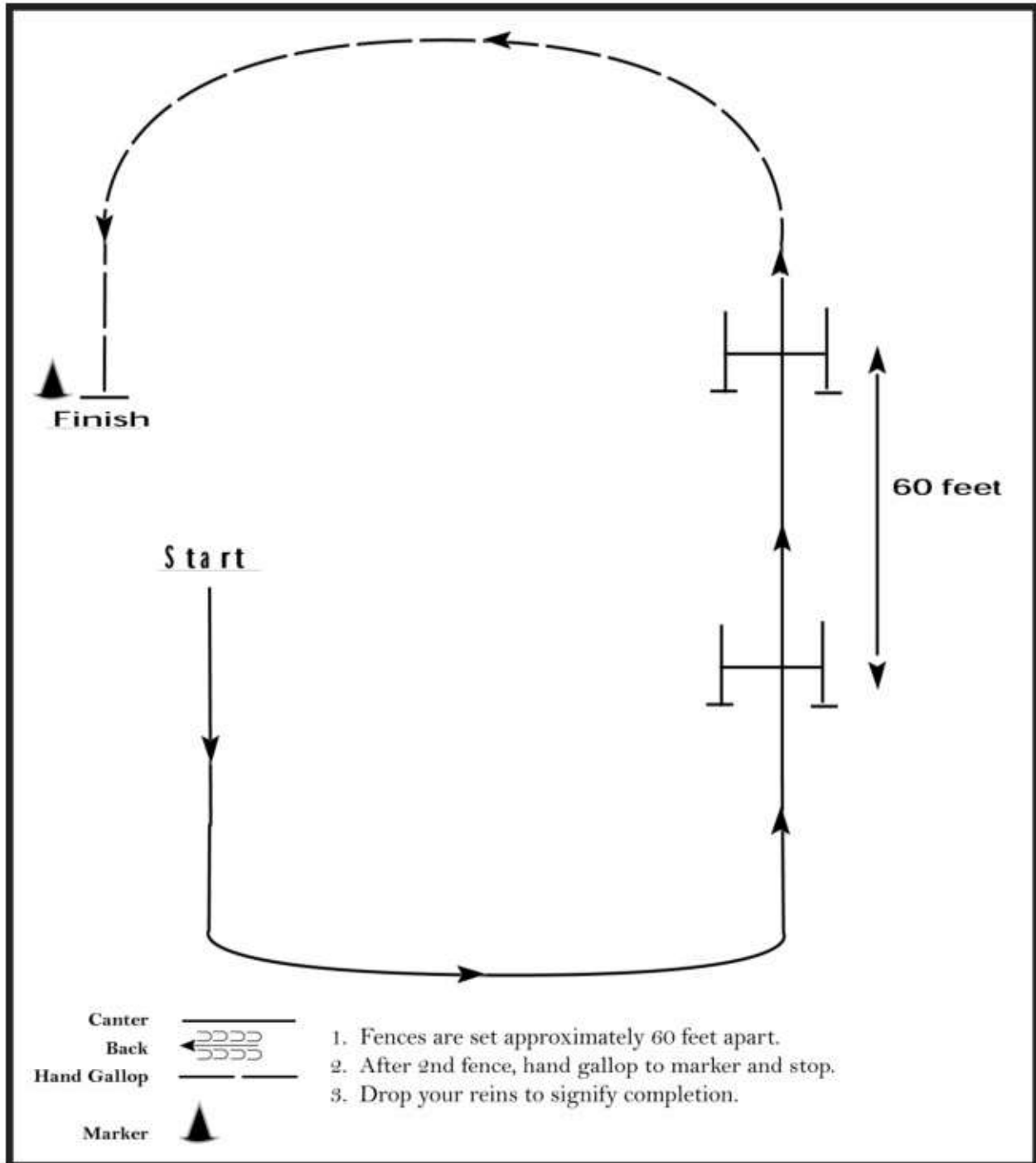

**Pattern Provided by:**

*Wyoming 4-H*

# Wyoming 4-H

## Hunter Hack (Senior) -4

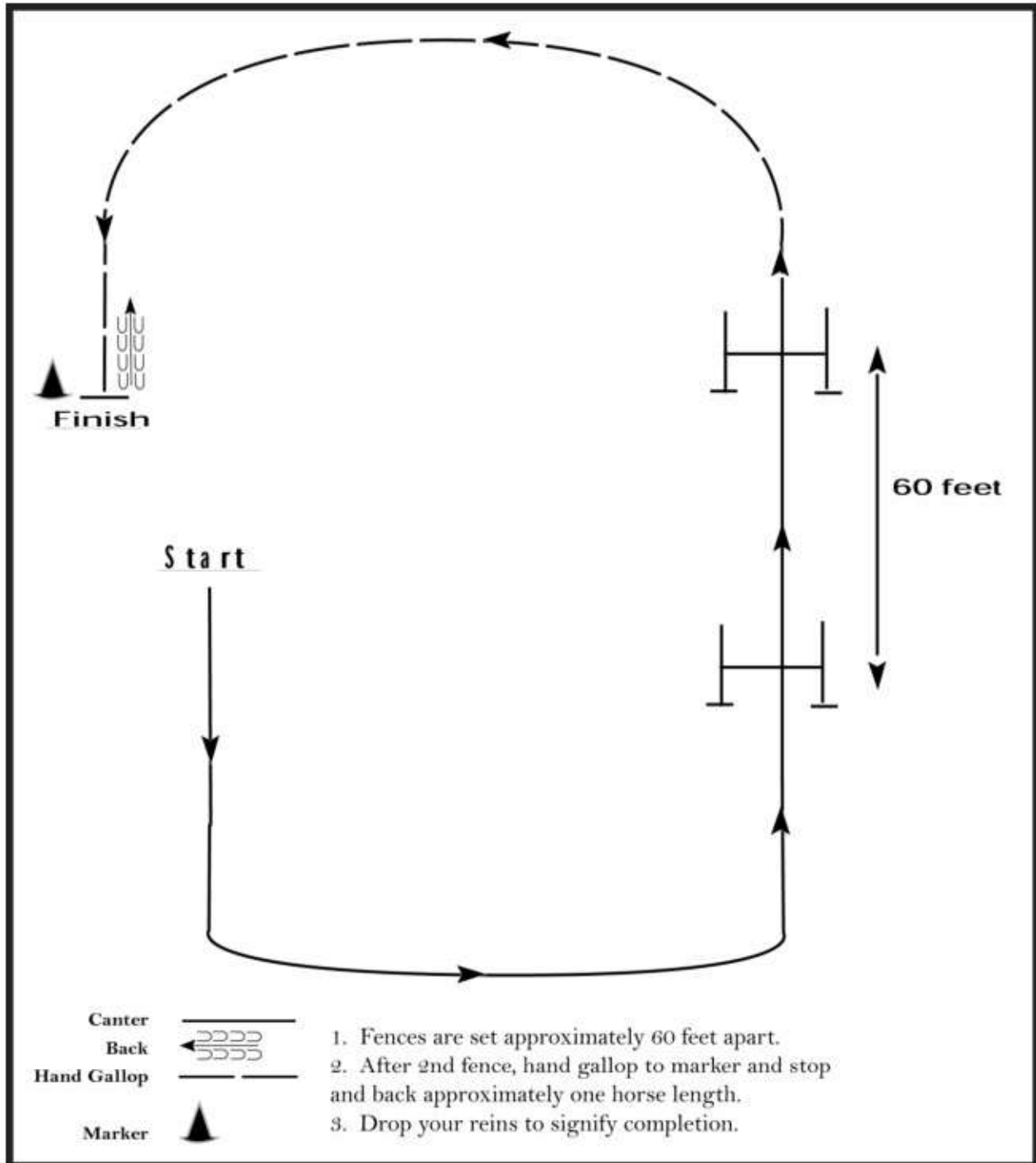

**Pattern Provided by:**

*Wyoming 4-H*

# Wyoming 4-H

## Junior/Intermediate Programmed Ride

<b>Purpose:</b> To confirm that the horse's muscles are supple and loose and that it moves freely forward in a clear and steady rhythm, accepting contact with the bit.			<b>Conditions:</b> Arena: 20 X 40 Meters Average Time: 4 Min Suggested Scheduling Time: 6 Min Maximum Possible Points: 230		
<b>Instruction:</b> All trot work may be ridden sitting or rising. Transitions in to and out of the halt may be made through the walk. Test may be called.					
<b>New Movements:</b> Five seconds immobility at halt. Free walk on a long rein					
			Coefficient		
	TEST	DIRECTIVE IDEAS	POINTS	TOTAL	REMARKS
1.	A X	Enter working trot Halt, Salute Proceed working trot			
2.	C E X	Track left Turn left Circle left 20 m			
3.	X B	Circle right 20m Turn left			
4.	C	Halt 5 seconds, proceed working walk			
5.	HXF F	Free walk on long rein Working walk		2	
6.	A E-B	Working trot Half circle right 20m			
7.	B	Working canter right lead			
8.	B B	Circle right 20m Straight ahead			
9.	F KXM	Working trot Change rein			
10.	M E-B	Working trot Half circle left 20 m			
11.	B	Working canter left lead and immediately:			
12.	B B	Circle left 20m Straight ahead			
13.	M HXF	Working trot Change rein			
14.	A X	Down centerline Halt, Salute (leave arena at free walk on long rein at A)			

Pattern Provided by: *Wyoming 4-H*

# Wyoming 4-H

COLLECTIVE MARKS:	Coefficient		Remarks
	Points	Total	
<b>GAITS</b> (freedom and regularity)	2		
<b>IMPULSION</b> (desire to move forward, elasticity of the steps, suppleness of the back, engagement of the hindquarters)	2		
<b>SUBMISSION</b> (attention and confidence, harmony, lightness and ease of movements, acceptance of the bridle, lightness of the forehand)	2		
<b>RIDER</b> (position and seat, correctness and effect of the aids)			
<b>FURTHER REMARKS:</b>	Subtotal: _____ Errors: ( - _____ ) Total Points _____		



## Junior/Intermediate Programmed Ride



**Purpose:** To confirm that the horse's muscles are supple and loose and that it moves freely forward in a clear and steady rhythm, accepting contact with the bit

\_\_\_\_\_  
Name of Competition

\_\_\_\_\_  
Date

\_\_\_\_\_  
Name and Number of horse

\_\_\_\_\_  
Name of Rider

**Conditions:**

Arena: 20 X 40 Meters

Average Time: 4 Min

Suggested Scheduling Time: 6 Min

Maximum Possible Points: 230

### FINAL SCORE

\_\_\_\_\_  
Points

\_\_\_\_\_  
Percent

\_\_\_\_\_  
Placing

\_\_\_\_\_  
Name of Judge

Pattern Provided by: *Wyoming 4-H*

# Wyoming 4-H

## Senior Programmed Ride

<b>Purpose:</b> To confirm that the horse's muscles are supple and loose and that it moves freely forward in a clear and steady rhythm, accepting contact with the bit.			<b>Conditions:</b> Arena: 20 X 40 Meters Average Time: 4 Min Suggested Scheduling Time: 6 Min Maximum Possible Points: 240		
<b>Instruction:</b> All trot work may be ridden sitting or rising. Transitions in to and out of the halt may be made through the walk. Test may be called.					
<b>New Movements:</b> 15m circles at the trot and canter. Lengthened stride in the trot.					
			Coefficient		
	TEST	DIRECTIVE IDEAS	POINTS	TOTAL	REMARKS
1. A X	Enter working trot Halt, Salute Proceed working trot	Straightness on centerline, transitions, quality of halt and trot			
2. C B	Track right Circle right 15m	Quality of turn at C, quality of trot, roundness and size of circle			
3. KXM M	Lengthen stride in trot Working trot	Straightness, quality of lengthened trot and of transitions			
4. E	Circle left 15m	Quality of trot, roundness and size of circle			
5. A	Halt 5 seconds, proceed working walk	Quality of halt and transitions		2	
6. FXH H	Free walk on a long rein Working walk	Straightness, quality of free walk and of transitions.			
7. C M	Working trot Working canter right lead	Calmness and smoothness of depart			
8. B	Circle right 15m	Quality of canter, roundness and size of circle			
9. KXM X M	Change rein Working trot Working canter left lead	Straightness, calmness and smoothness of transitions			
10. E	Circle left 15m	Quality of canter, roundness and size of circle			
11. FXH X	Change rein Working trot	Straightness, calmness and smoothness of transitions			
12. MXK K	Lengthen stride in trot Working trot	Straightness, quality of lengthened trot and of transitions			
13. A X	Down centerline Halt, Salute  (Leave arena at free walk on a long rein at A)	Straightness on centerline, quality of halt.			

Pattern Provided by: *Wyoming 4-H*

# Wyoming 4-H

COLLECTIVE MARKS:	Coefficient		Remarks
	Points	Total	
<b>GAITS</b> (freedom and regularity)	2		
<b>IMPULSION</b> (desire to move forward, elasticity of the steps, suppleness of the back, engagement of the hindquarters)	2		
<b>SUBMISSION</b> (attention and confidence, harmony, lightness and ease of movements, acceptance of the bridle, lightness of the forehand)	2		
<b>RIDER</b> (position and seat, correctness and effect of the aids)			
<b>FURTHER REMARKS:</b>	Subtotal: _____ Errors: ( - _____ ) Total Points _____		



## Senior Programmed Ride



**Purpose:** To confirm that the horse's muscles are supple and loose and that it moves freely forward in a clear and steady rhythm, accepting contact with the bit.

\_\_\_\_\_  
Name of Competition

\_\_\_\_\_  
Date

\_\_\_\_\_  
Name and Number of horse

\_\_\_\_\_  
Name of Rider

**Conditions:**

Arena: 20 X 40 Meters

Average Time: 4 Min

Suggested Scheduling Time: 6 Min

Maximum Possible Points: 240

### FINAL SCORE

\_\_\_\_\_  
Points

\_\_\_\_\_  
Percent

\_\_\_\_\_  
Placing

\_\_\_\_\_  
Name of Judge

Pattern Provided by: *Wyoming 4-H*

# Wyoming 4-H

## Wyoming Working Cow Dry Work Pattern (Junior)

1. Trot past center
2. Stop and back to center
3. Begin work to the right, pick up right lead and do first half of figure 8
4. Change leads (simple or flying) in center and complete figure 8
5. Stop in center
6. Walk to Judge

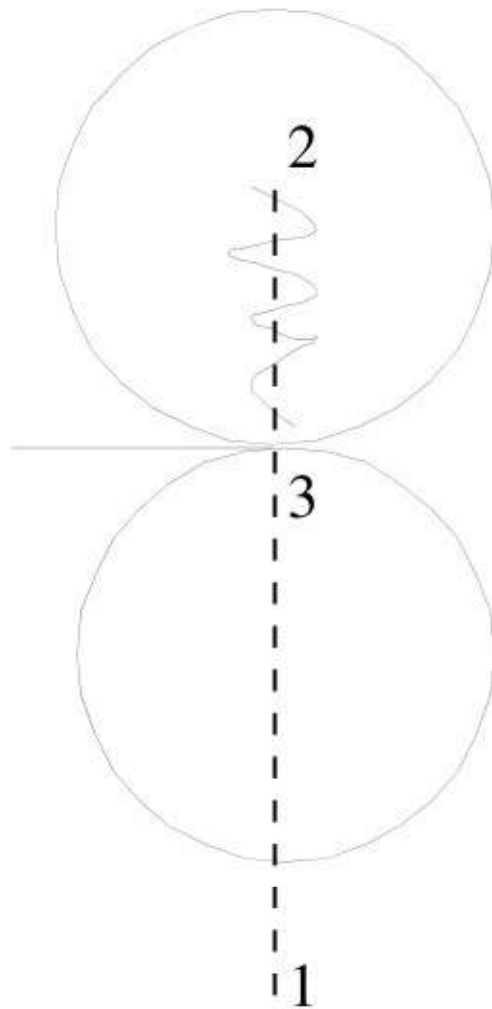

Pattern Provided by: *Wyoming 4-H*

# Wyoming 4-H

## Working Cow – Cow Pattern (Intermediate)

### Explanation

Please note: This diagram is not drawn to scale. It is simply to show the arena layout and a pattern explanation.

1. After completing the reining pattern call or cow at the center of the arena
2. Take cow down past four cones.
3. Take cow around 5<sup>th</sup> cone.
4. Put cow back through gate.

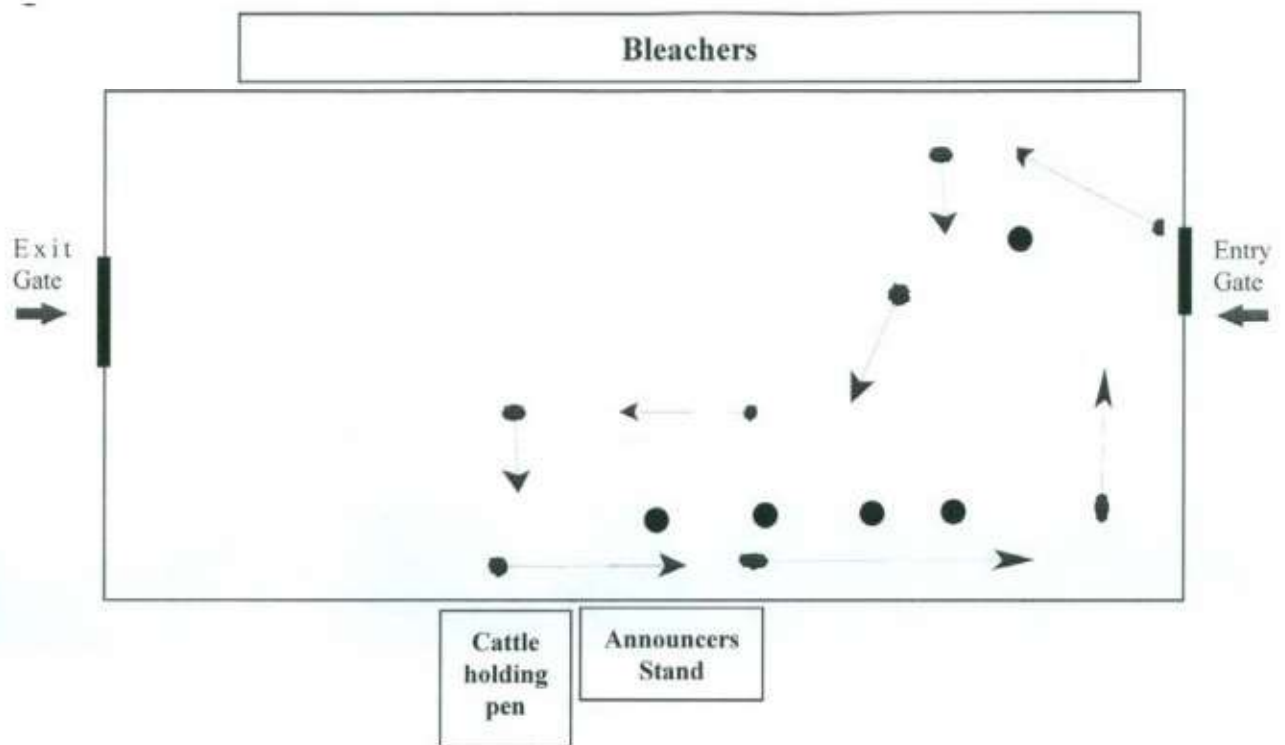

Pattern Provided by: *Wyoming 4-H*

# Wyoming 4-H

## Working Cow – Cow Pattern (Junior)

### Explanation

Please note: this diagram is not drawn to scale. It is simply to show the arena layout and a pattern explanation

1. Do dry work (reining pattern).
2. Call for cow at the center of the arena.
3. Take cow past cone 1
4. Take cow down to cone 2.
5. Turn cow into the fence at cone 2.
6. Take cow back to cone 1.
7. Put cow back through gate.

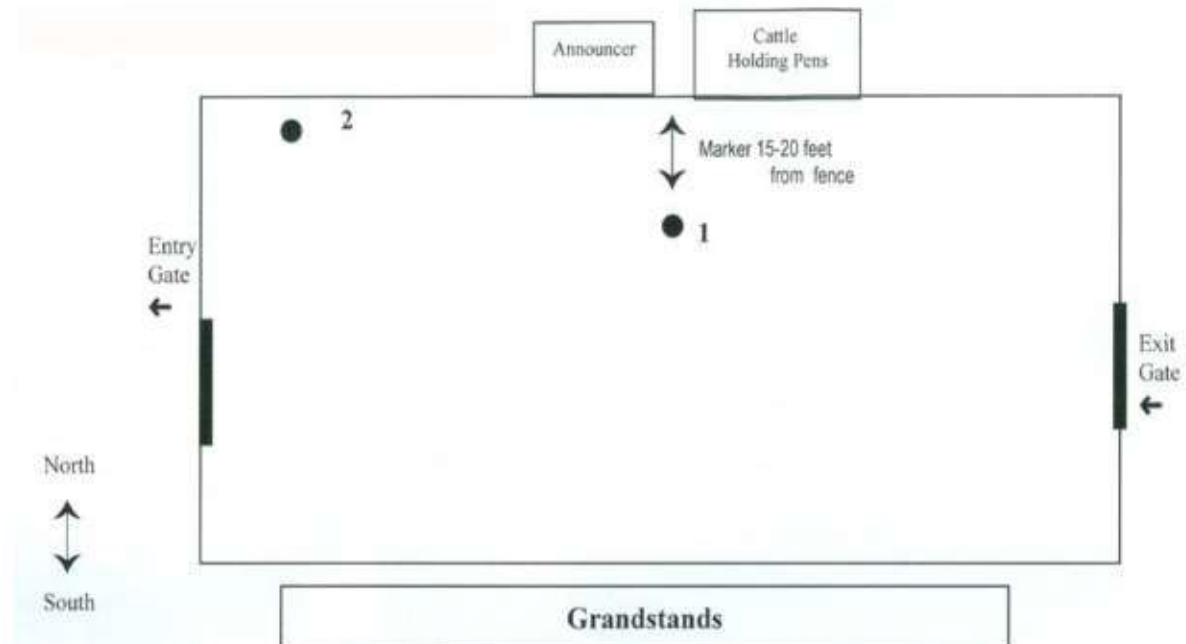

Pattern Provided by: *Wyoming 4-H*

# Wyoming 4-H

## Working Cow - Cow Pattern (Senior)

### Pattern:

Upon receiving a cow, contestants shall hold each cow in the prescribed area of the arena for sufficient time to demonstrate a horse's ability to control the cow.

1. Take the cow down the fence,
2. Make at least one turn in each direction on the fence.
3. Take the animal to an open part of the arena and circle the animal at least once in each direction.

This exercise is ideal fence work; however, a judge should take into consideration the size of the arena, the ground condition, and the disposition of the cattle.

### Consideration Guidelines:

At the judge's discretion, cattle work may be done immediately following each individual's pattern work or immediately after completion of pattern work by all horses being exhibited.

- A. The cattle-working portion must be completed within two minutes.
- B. At the judge's discretion, a rerun may be given if a cow being worked leaves the arena, is blind, or won't run.
- C. At the judge's discretion, the run may be terminated when it poses a threat to the safety of a rider or the livestock.

Pattern Provided by: *Wyoming 4-H*

# Wyoming 4-H

## Wyoming 4-H Working Cow – Dry Work (Senior)-1

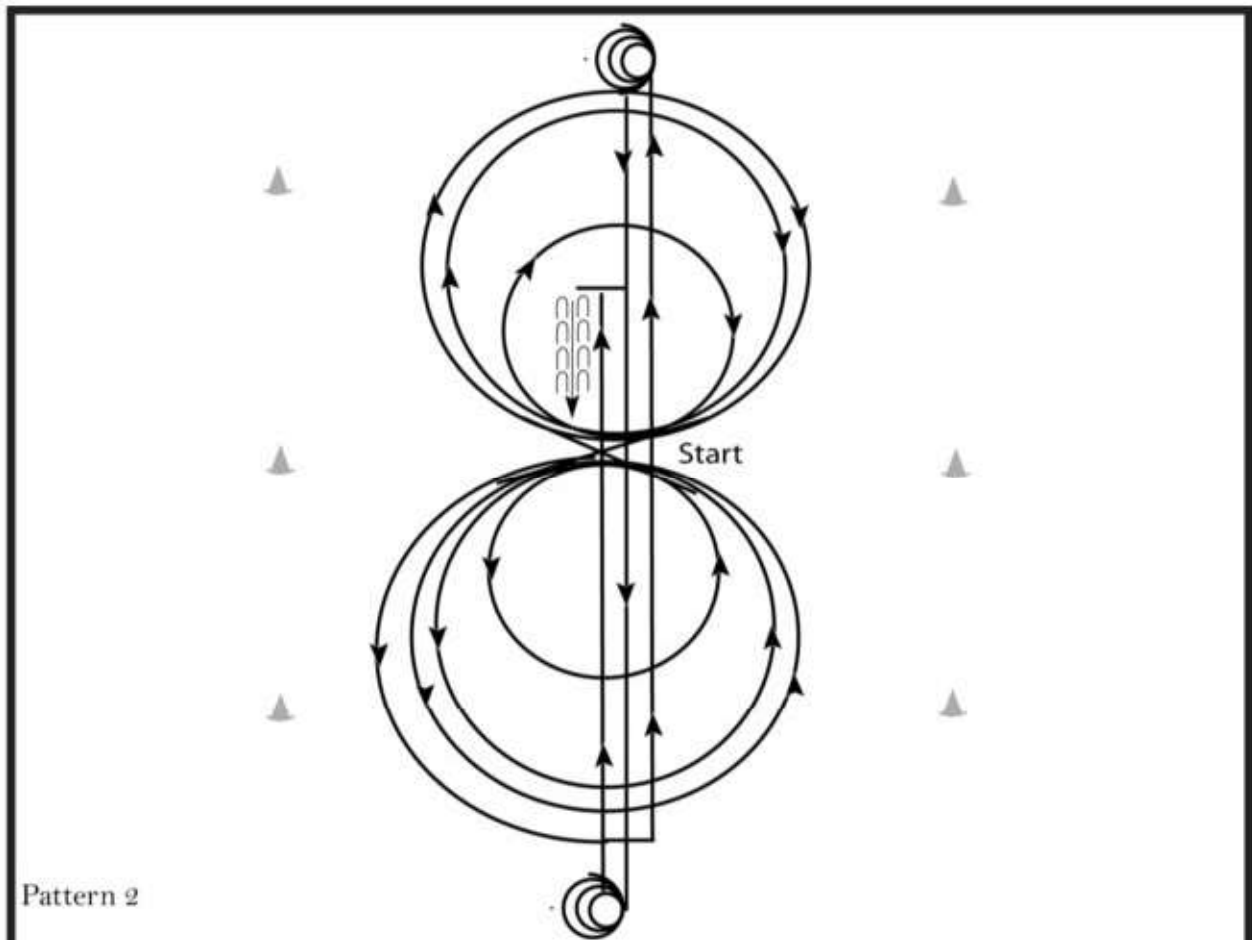

Pattern 2

Trot to center of arena, stop. Start pattern facing towards judge.

1. Beginning on the left lead, complete 3 circles to the left. The first one large and fast, the second small and slow, the third large and fast. Change leads at the center of arena.
2. Complete 3 circles to the right. The first one large and fast, the second small and slow, and the third large and fast. Change leads at the center of the arena.
3. Continue loping to run down.
4. Run to far end past the marker to a sliding stop. Hesitate.
5. Complete 3 1/2 spins to the left. Hesitate.
6. Run to far end past marker to a sliding stop. Hesitate.
7. Complete 3 1/2 spins to the right. Hesitate.
8. Run past center marker to a sliding stop. Hesitate.
9. Back at least 10 feet. Hesitate to complete pattern.

**Pattern Provided by:**

*Wyoming 4-H*

# Wyoming 4-H

## Wyoming 4-H Working Cow – Dry Work (Senior)-2

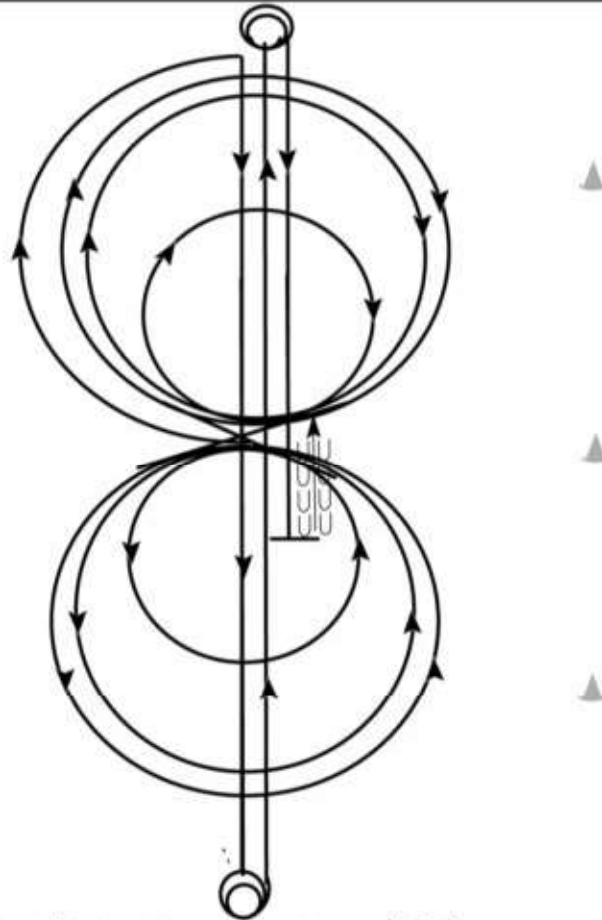

Pattern 3

Trot to center of arena, stop. Start pattern facing towards judge.

1. Begin on right lead complete 3 circles to the right, 2 big fast circles followed by 1 small slow circle, change to left lead.
2. Complete 3 circles to the left, first 2 big, fast circles followed by 1 small slow circle. Change to right lead.
3. Continue loping around end of arena without breaking gait.
4. Run up center of arena to far end past the end marker and come to a sliding stop.
5. Complete 2 1/2 spins to the right.
6. Run up center of arena past the end marker, come to a sliding stop.
7. Complete 2 1/2 spins to the left.
8. Run back to middle of the arena past the center marker and come to a sliding stop.
9. Back at least 10 feet in a straight line.
10. Hesitate to complete pattern.

**Pattern Provided by:**

*Wyoming 4-H*

# Wyoming 4-H

## Wyoming 4-H Working Cow – Dry Work (Senior)-3

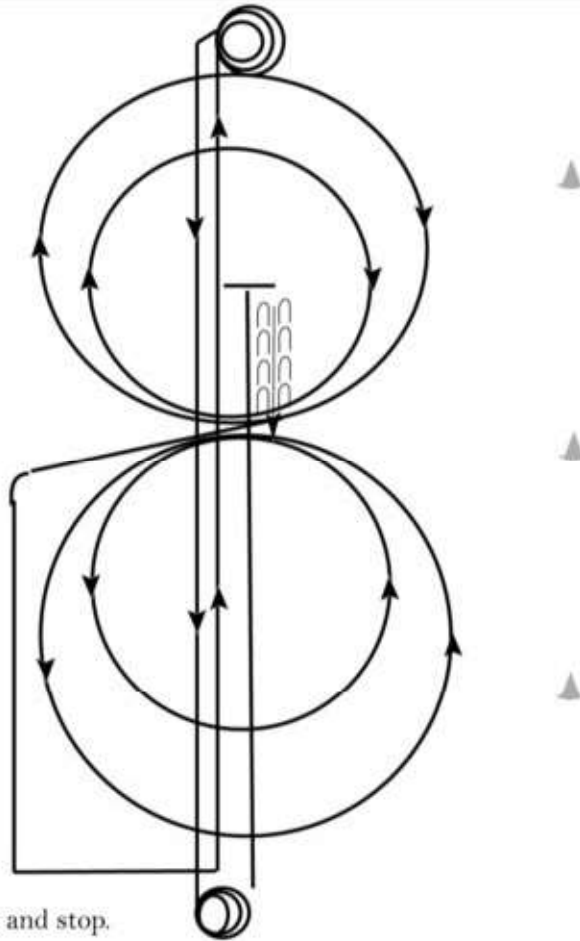

### Pattern 5

1. Start at end of arena.
2. Run past the center marker and stop.
3. Back up at least 10 feet.
4. Complete 1/4 turn to the left.
5. Complete 2 circles to the left, the first one large and fast and the second small and slow. Change leads at the center of the arena.
6. Complete two circles to the right, the first one small and slow, the second large and fast. Change leads at the center of the arena.
7. Continue around the end of arena without breaking gait or changing leads, run down center of arena past end marker, come to a square sliding stop.
8. Complete 3 1/2 spins to the right.
9. Run down center of arena past end marker and come to a square sliding stop.
10. Complete 3 1/2 spins to the left.
11. Hesitate to complete pattern.

**Pattern Provided by:**

*Wyoming 4-H*

# Wyoming 4-H

## Wyoming 4-H Working Cow - Dry Work (Senior)-4

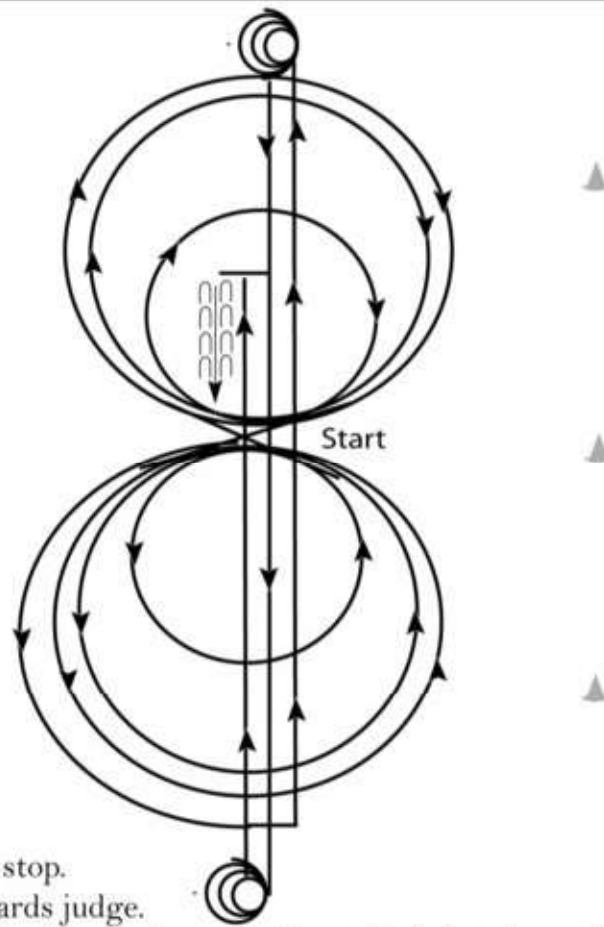

Pattern 8

Trot to center of arena, stop.

Start pattern facing towards judge.

1. Beginning on the left lead, complete 3 circles to the left; 2 large, fast circles, then one small slow circle. Change leads to the right.
2. Complete 3 circles to the right; 2 large, fast circles, then 1 small slow circle. Change leads to the left.
3. Continue around end of arena without breaking gait or changing leads. Run down center of arena past end marker come to square sliding stop.
4. Complete 3 1/2 spins to the left.
5. Run down center of arena past end marker and come to a square sliding stop.
6. Complete 3 1/2 spins to the right.
7. Run down center of arena past center marker come to a square sliding stop.
8. Back at least 10 feet. Hesitate to complete pattern.

**Pattern Provided by:**

*Wyoming 4-H*

# Wyoming 4-H

## Wyoming 4-H Working Cow – Dry Work (Senior)-5

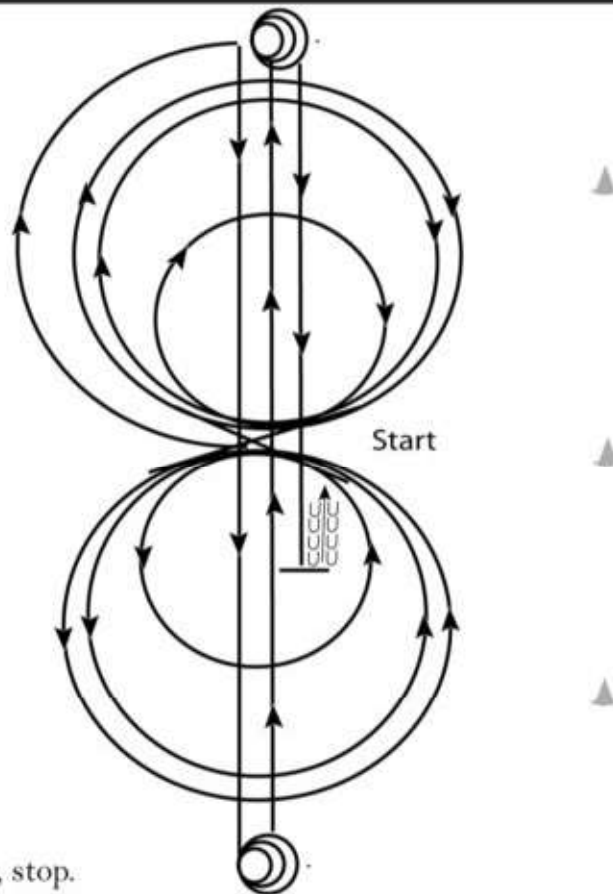

Pattern 9

Trot to center of arena, stop.

Start pattern facing towards judge.

1. Beginning on the right lead, complete 3 circles to the right; the first circle small and slow followed by two large fast circles. Change leads at the center of the arena.
2. Complete 3 circles to the left, the first circle small and slow followed by two large fast circles. Change leads at the center of the arena.
3. Continue around end of arena without breaking gait or changing leads, run down center of arena past end marker, and execute a square sliding stop.
4. Complete 3 1/2 spins to the left.
5. Run down center of arena past end marker and execute a square sliding stop.
6. Complete 3 1/2 spins to the right.
7. Run down center of arena past center marker and execute a square sliding stop.
8. Back at least 10 feet. Hesitate to complete pattern.

**Pattern Provided by:**

*Wyoming 4-H*

# Wyoming 4-H

## Wyoming 4-H Working Cow – Dry Work (Senior)-6

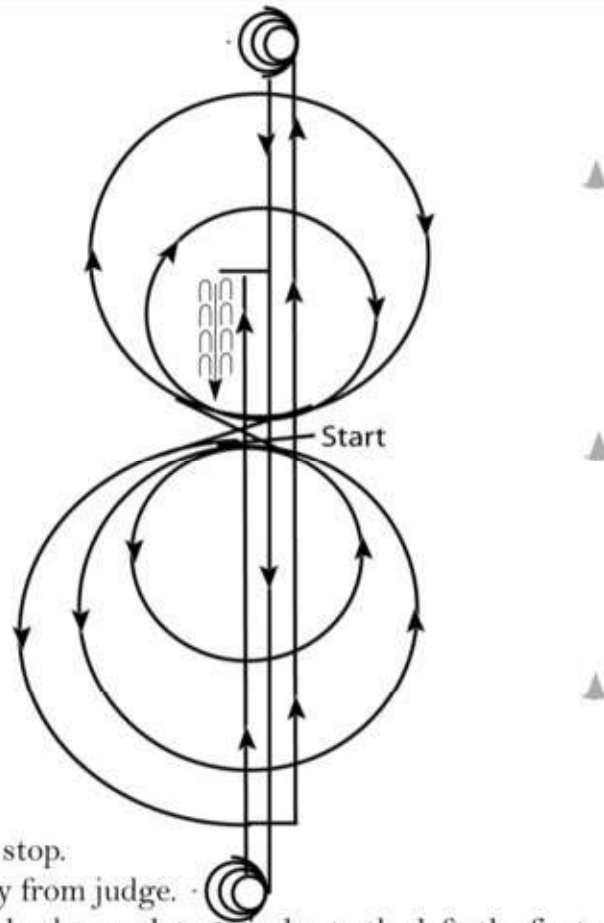

Pattern 11

Trot to center of arena, stop.

Start pattern facing away from judge.

1. Beginning on the left lead, complete 2 circles to the left; the first circle large and fast, the second circle small and slow. Change leads to the right.
2. Complete 2 circles to the right; the first circle large and fast, the second circle small and slow. Change leads to the left.
3. Continue around end of arena without breaking gait or changing leads. Run down center of arena past end marker and execute a square sliding stop.
4. Complete 3 1/2 spins to the left.
5. Run down center of arena past end marker and execute a square sliding stop.
6. Complete 3 1/2 spins to the right.
7. Run down center of arena past center marker and execute a square sliding stop.
8. Back at least 10 feet.
9. Hesitate to complete pattern.

**Pattern Provided by:**

*Wyoming 4-H*

# Wyoming 4-H

## Wyoming 4-H Working Cow – Dry Work (Senior)-6

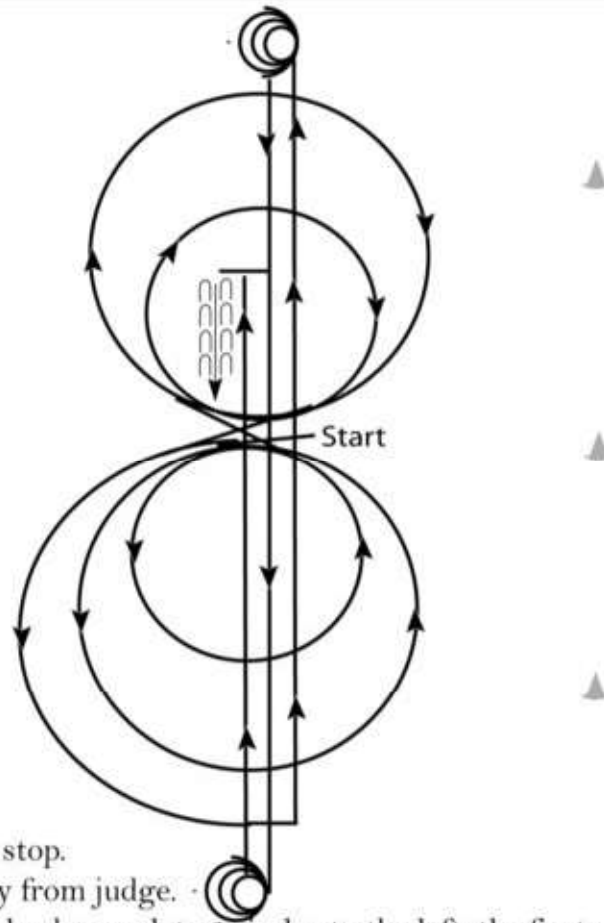

Pattern 11

Trot to center of arena, stop.

Start pattern facing away from judge.

1. Beginning on the left lead, complete 2 circles to the left; the first circle large and fast, the second circle small and slow. Change leads to the right.
2. Complete 2 circles to the right; the first circle large and fast, the second circle small and slow. Change leads to the left.
3. Continue around end of arena without breaking gait or changing leads. Run down center of arena past end marker and execute a square sliding stop.
4. Complete 3 1/2 spins to the left.
5. Run down center of arena past end marker and execute a square sliding stop.
6. Complete 3 1/2 spins to the right.
7. Run down center of arena past center marker and execute a square sliding stop.
8. Back at least 10 feet.
9. Hesitate to complete pattern.

**Pattern Provided by:**

*Wyoming 4-H*

# Wyoming 4-H

## Wyoming 4-H Working Cow - Dry Work (Intermediate)-4

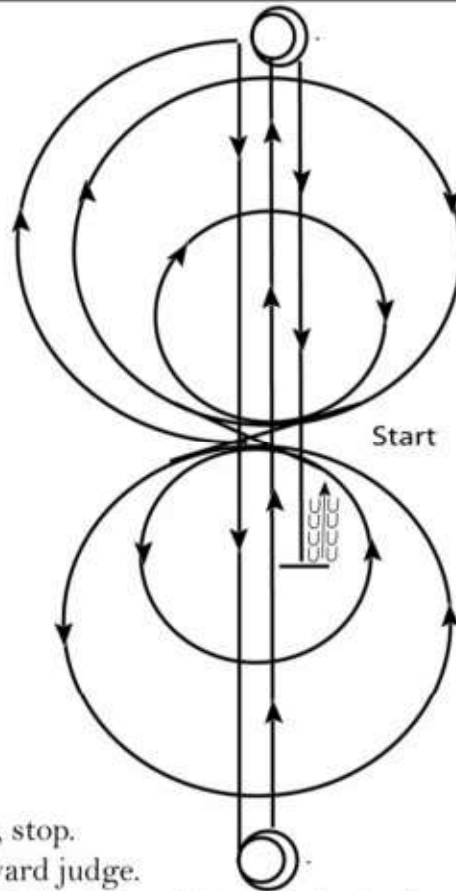

Pattern 12

Trot to center of arena, stop.

Start pattern facing toward judge.

1. Beginning on the right lead, complete 2 circles to the right; the first circle large and fast and the second circle small and slow. Change leads at the center of the arena.
2. Complete 2 circles to the left, the first circle large and fast and the second small and slow. Change leads at the center of the arena.
3. Continue around end of arena without breaking gait or changing leads, run down center of arena past end marker, and execute a square sliding stop.
4. Complete 2 1/2 spins to the left.
5. Run down center of arena past end marker and execute a square sliding stop.
6. Complete 2 1/2 spins to the right.
7. Run down center of arena past center marker and execute a square sliding stop.
8. Back at least 10 feet.
9. Hesitate to complete pattern.

**Pattern Provided by:**

*Wyoming 4-H*

# Wyoming 4-H

## Wyoming 4-H Western Riding (Junior/Intermediate)

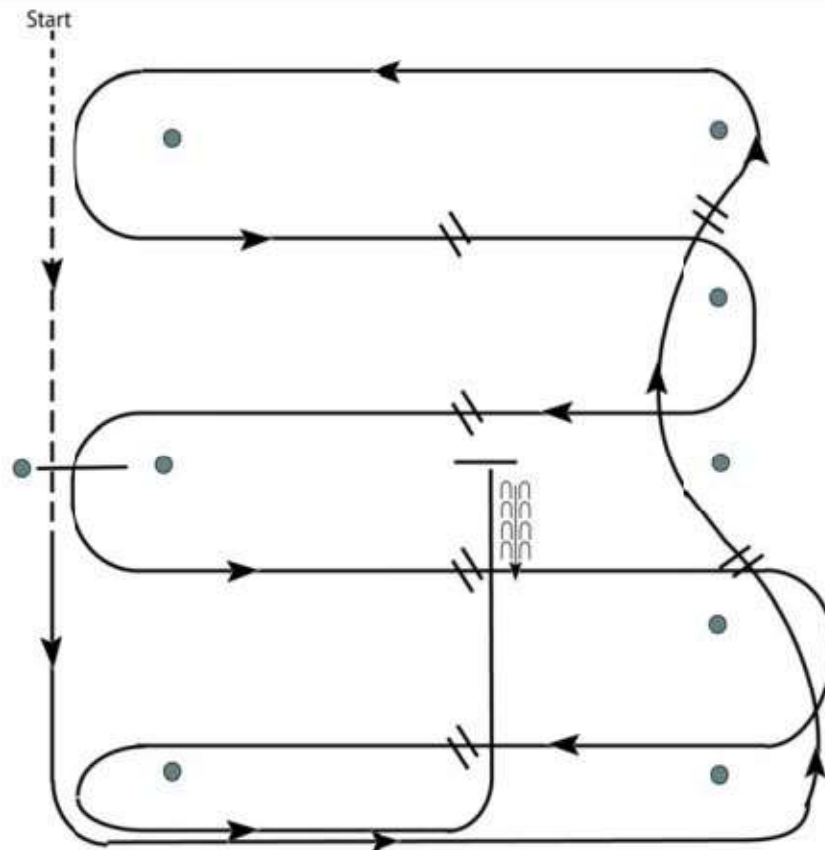

1. Walk at least 15' & jog over log.
2. Transition to left lead and lope around end.
3. First line change.
4. Second line change. Lope around end of arena
5. First crossing change.
6. Second crossing change.
7. Lope over log.
8. Third crossing change.
9. Fourth crossing change.
10. Lope up the center, stop and back.

**Pattern Provided by:**

*Wyoming 4-H*

# Wyoming 4-H

## Wyoming 4-H Western Horsemanship (Intermediate) -1

Be ready at A.

1. Jog from A to B.
2. Extend the jog in a circle to the right at B.
3. Lope on the left lead to C and circle to the left.
4. Continue to lope to D.
5. Stop at D and back one horse length.

Retire to the rail or line up at a jog.

Walk	-----
Jog	- - - - -
Extended Jog	— — — —
Lope	—————
Leg Yield	
Lead Change	↘
Back	← c c c c
Marker	⊙ B
Sidepass	← — — — — →

Pattern Provided by:

*Wyoming 4-H*

# Wyoming 4-H

## Wyoming 4-H Western Horsemanship (Intermediate) -1

Be ready at A.

1. Jog from A to B.
2. Extend the jog in a circle to the right at B.
3. Lope on the left lead to C and circle to the left.
4. Continue to lope to D.
5. Stop at D and back one horse length.

Retire to the rail or line up at a jog.

Walk	-----
Jog	- - - - -
Extended Jog	— — — —
Lope	—————
Leg Yield	
Lead Change	↘
Back	← c c c c c
Marker	⊙ B
Sidepass	← — — — — →

Pattern Provided by:

*Wyoming 4-H*

# Wyoming 4-H

## Wyoming 4-H Western Horsemanship (Intermediate) -2

Be ready at A.

1. Jog from A to B.
2. Stop at B and perform a 360 degree turn to the right.
3. Lope on the right lead to C
4. Even with C, break to an extended jog and circle to the right.
5. Stop at C and back one horse length

Retire to the rail or line up at a jog.

Walk	-----
Jog	- - - - -
Extended Jog	- - - - -
Lope	—————
Leg Yield	
Lead Change	///
Back	←←←←←
Marker	(B)
Sidepass	←←

**Pattern Provided by:**

*Wyoming 4-H*

# Wyoming 4-H

## Wyoming 4-H Western Horsemanship (Intermediate) -3

Begin before A at a jog.

1. Jog from A to B.
2. At B, lope on the left lead and circle at B as shown. Stop facing B.
3. Turn 1 1/4 turn to the left.
4. Back one horse length.
5. Lope on the right lead to C. Stop at C.

Follow the instructions of your ring steward.

Walk	-----
Jog	-----
Extended Jog	-----
Lope	-----
Leg Yield	
Lead Change	↘
Back	←
Marker	⊙
Sidepass	←

Pattern Provided by:

*Wyoming 4-H*

# Wyoming 4-H

## Wyoming 4-H Western Horsemanship (Intermediate) -4

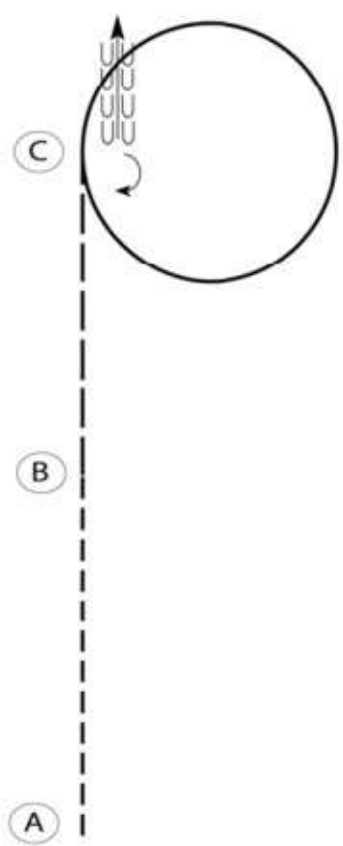

The diagram shows a vertical dashed line with points A, B, and C marked from bottom to top. At point C, a circle is drawn to the right. An arrow indicates a 180-degree turn to the right at point C. A legend on the right side of the diagram defines various horse movements with symbols: Walk (dashed line), Jog (long dashed line), Extended Jog (short dashed line), Lope (solid line), Leg Yield (vertical lines with horizontal ticks), Lead Change (diagonal lines), Back (line with arrows pointing left), Marker (circle with B), and Sidepass (line with arrows pointing left).

Be ready at A.

1. Jog from A to B.
2. Extend the jog to C.
3. At C, lope a circle to the right
4. Even with C, stop and do a 180 degree turn to the right.
5. Back one horse length
6. Retire to the rail or line up at a jog.

Walk	-----
Jog	- - - - -
Extended Jog	- - - - -
Lope	—————
Leg Yield	
Lead Change	— / —
Back	← ← ← ← ←
Marker	(B)
Sidepass	← ← ← ← ←

Pattern Provided by:

*Wyoming 4-H*

# Wyoming 4-H

## Wyoming 4-H Western Horsemanship (Intermediate) -5

The diagram shows a vertical dashed line with points A, B, C, D, and E marked from bottom to top. A circle is drawn to the right of the line, tangent to it at point B. An arrow at the top of the line points downwards towards point E, with the word 'Back' written vertically next to it. A legend on the right side of the diagram defines the symbols for different gaits and movements:

- Walk: Dashed line
- Jog: Long dashed line
- Extended Jog: Short dashed line
- Lope: Solid line
- Leg Yield: Vertical line with horizontal ticks
- Lead Change: Diagonal line with a slash
- Back: Arrow pointing left with 'Back' written above it
- Marker: Circle with the letter 'B' inside
- Sidepass: Two arrows pointing left

Be ready at A.

1. Jog from A to B.
2. Lope a circle to the right on the right lead.
3. Change leads at B.
4. Lope on the left lead to C.
5. Walk from C to D.
6. Jog from D to E.
7. Stop at E and back one horse length.

Retire to the rail or line up at a jog.

**Pattern Provided by:**

*Wyoming 4-H*

# Wyoming 4-H

## Wyoming 4-H Western Horsemanship (Intermediate)-6

1. Jog A to C.  
2. Stop at C and perform a 180 degree turn to the right  
3. Lope a circle around C on the right lead.  
4. Stop at C and perform a 90 degree turn to the left.  
5. Extended jog to D.  
6. Stop at D and back approximately one horse length.

Follow the instructions of your ring steward.

Walk	-----
Jog	-----
Extended Jog	-----
Lope	-----
Lead Change	
Back	
Marker	

**Pattern Provided by:**

*Wyoming 4-H*

# Wyoming 4-H

## Wyoming 4-H Western Horsemanship (Junior) -1

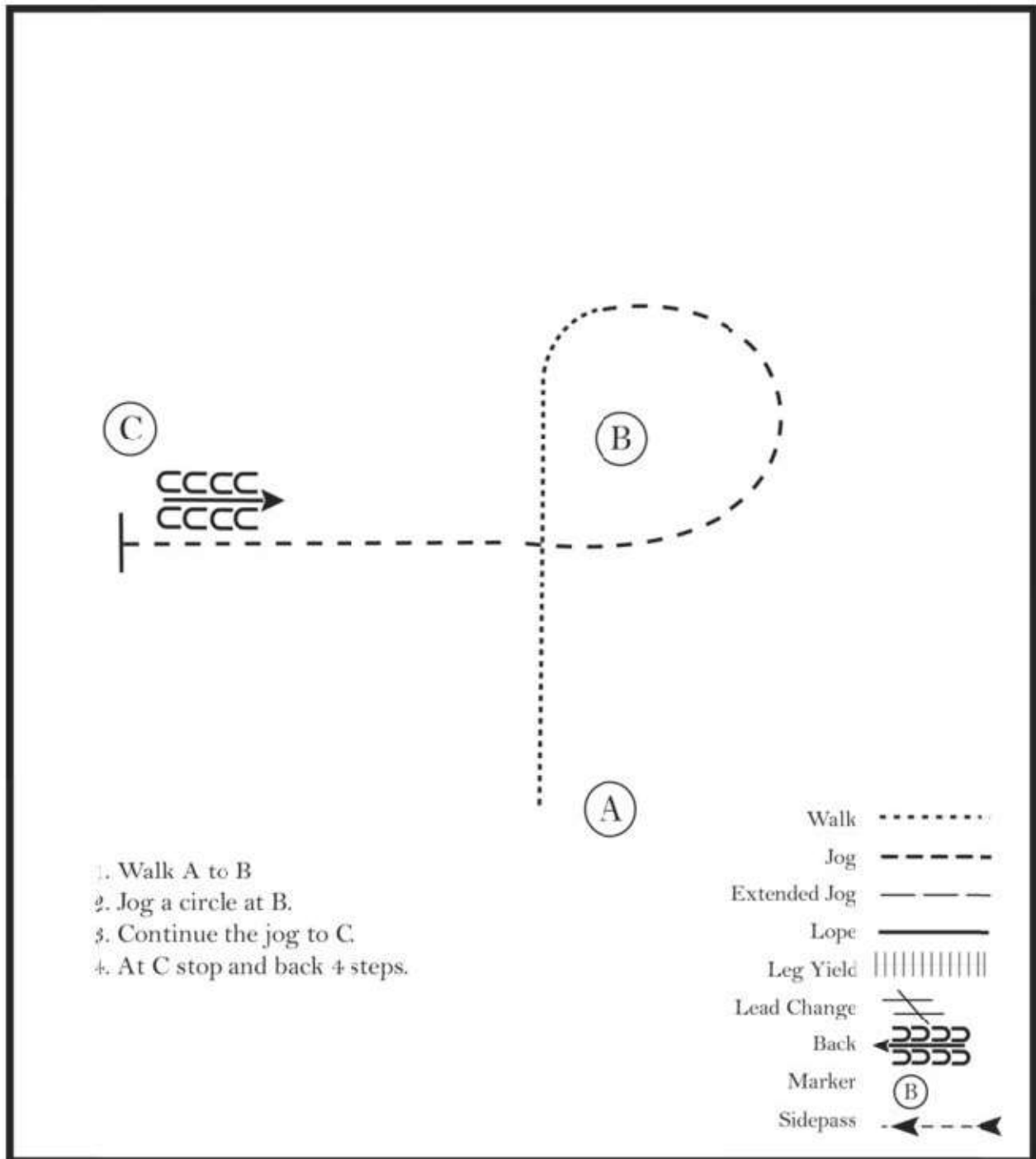

Pattern Provided by:

*Wyoming 4-H*

# Wyoming 4-H

## Wyoming 4-H Western Horsemanship (Junior) -1

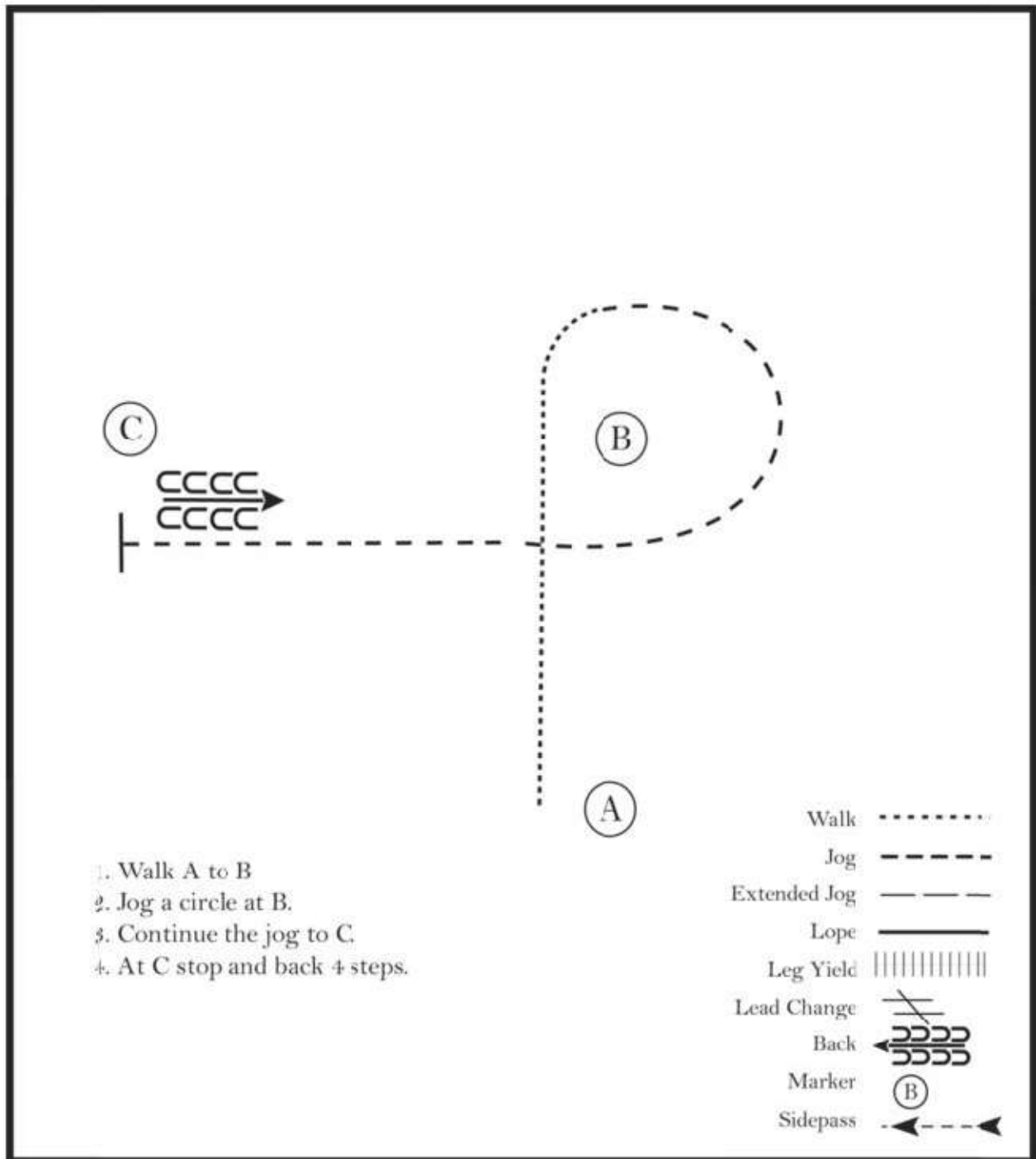

Pattern Provided by:

*Wyoming 4-H*

# Wyoming 4-H

## Wyoming 4-H Western Horsemanship (Junior) -2

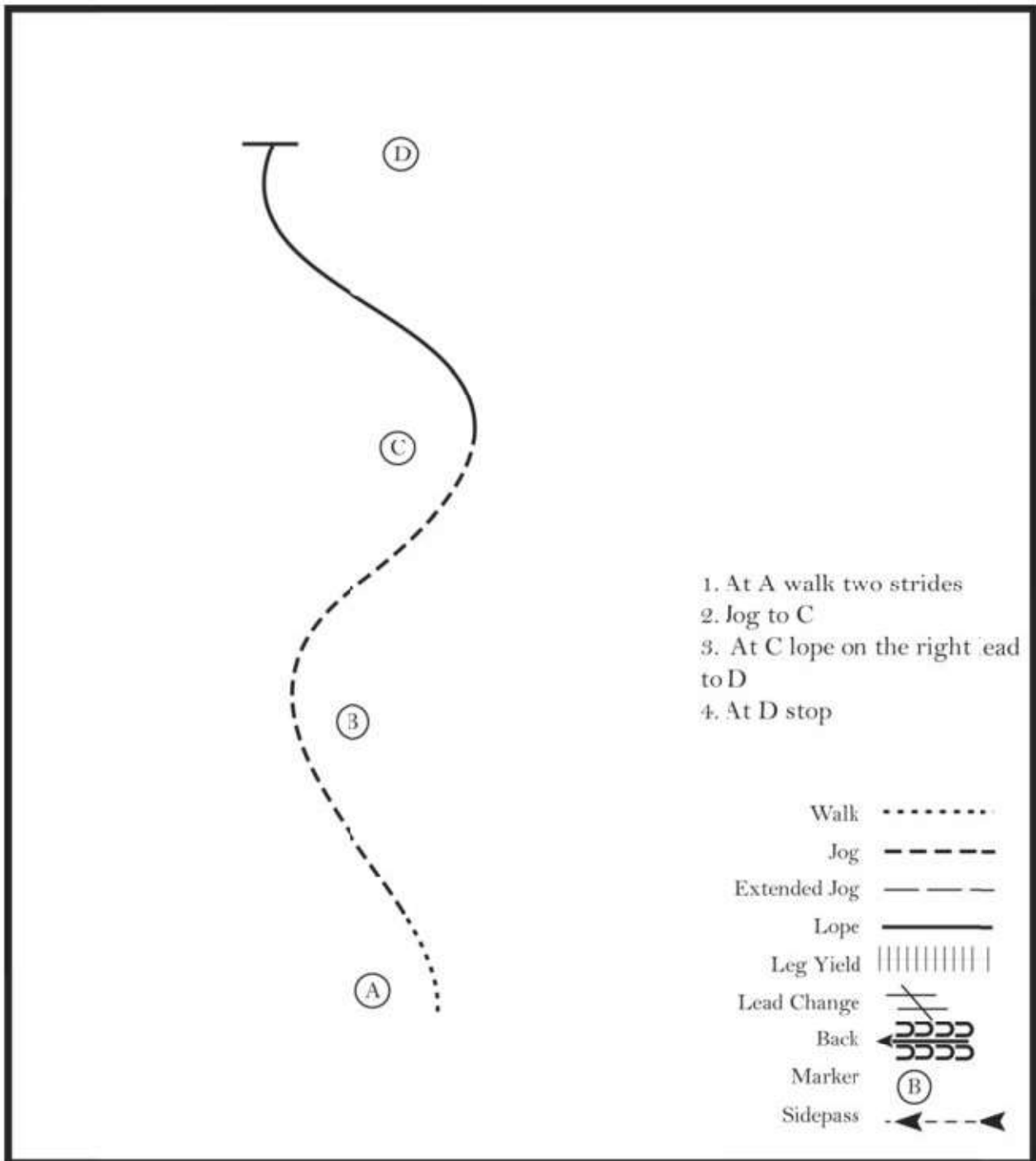

**Pattern Provided by:**

*Wyoming 4-H*

# Wyoming 4-H

## Wyoming 4-H Western Horsemanship (Junior) -3

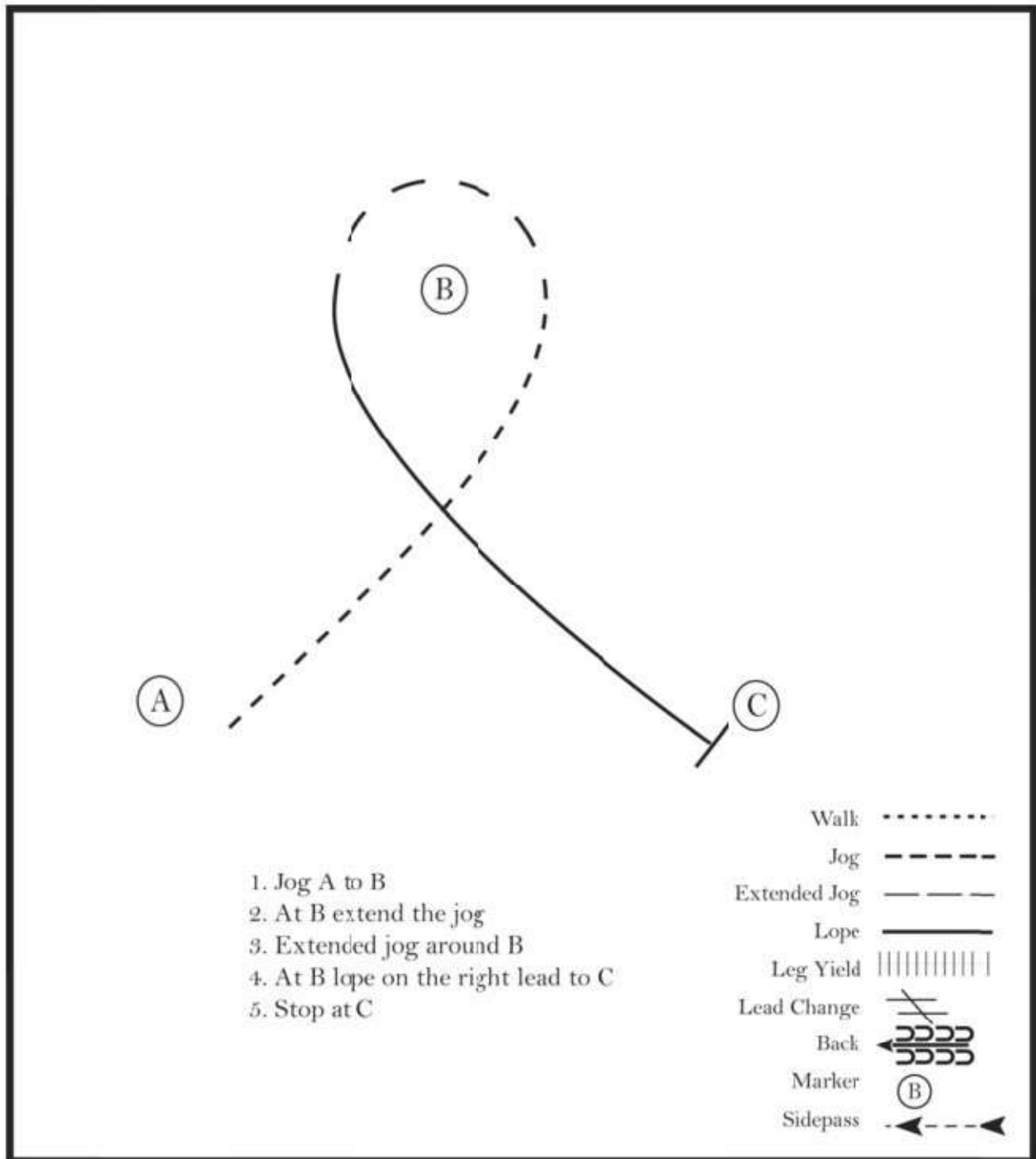

**Pattern Provided by:**

*Wyoming 4-H*

# Wyoming 4-H

## Wyoming 4-H Western Horsemanship (Junior) -4

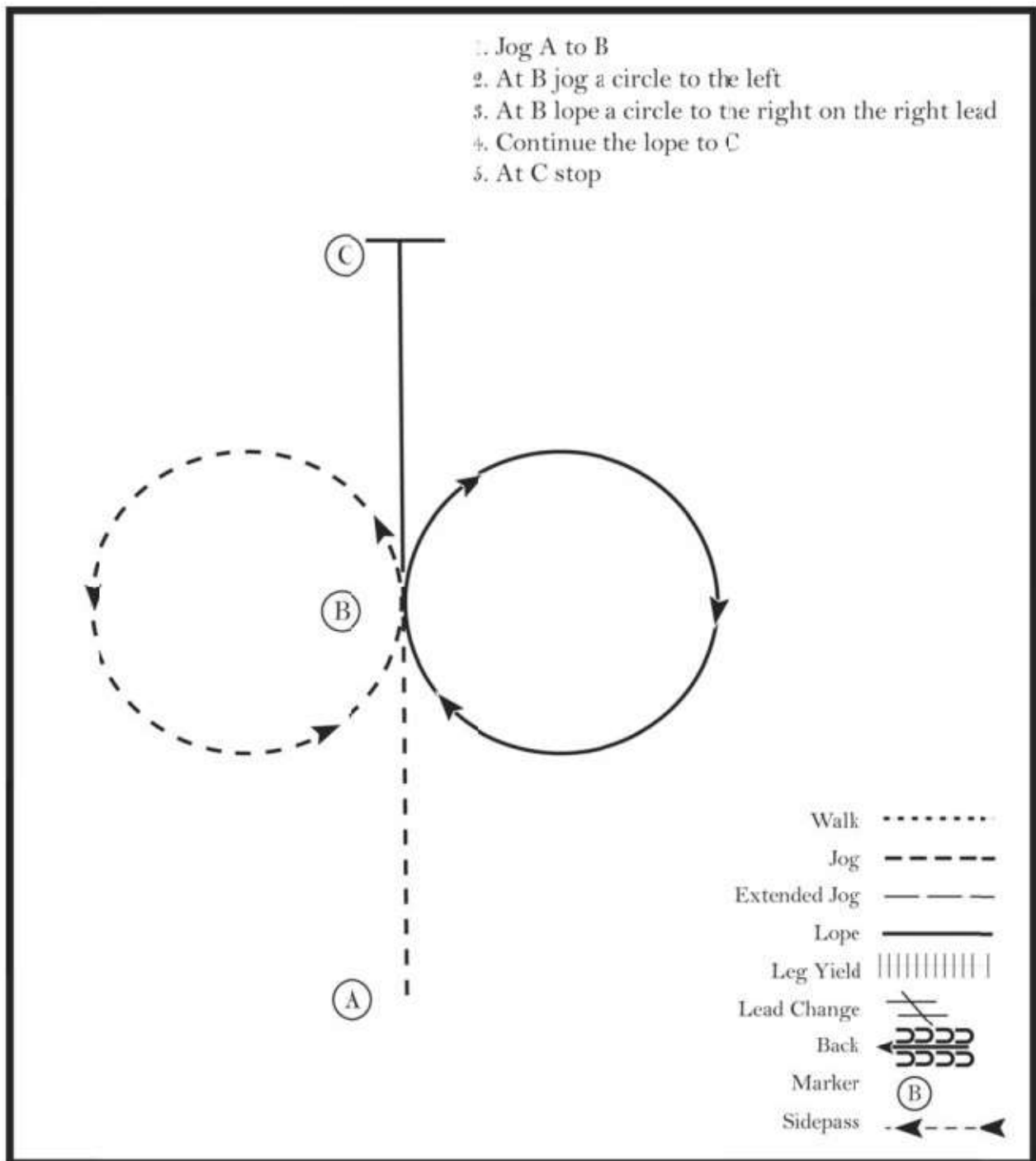

Pattern Provided by:

*Wyoming 4-H*

# Wyoming 4-H

## Wyoming 4-H Western Horsemanship (Junior) -5

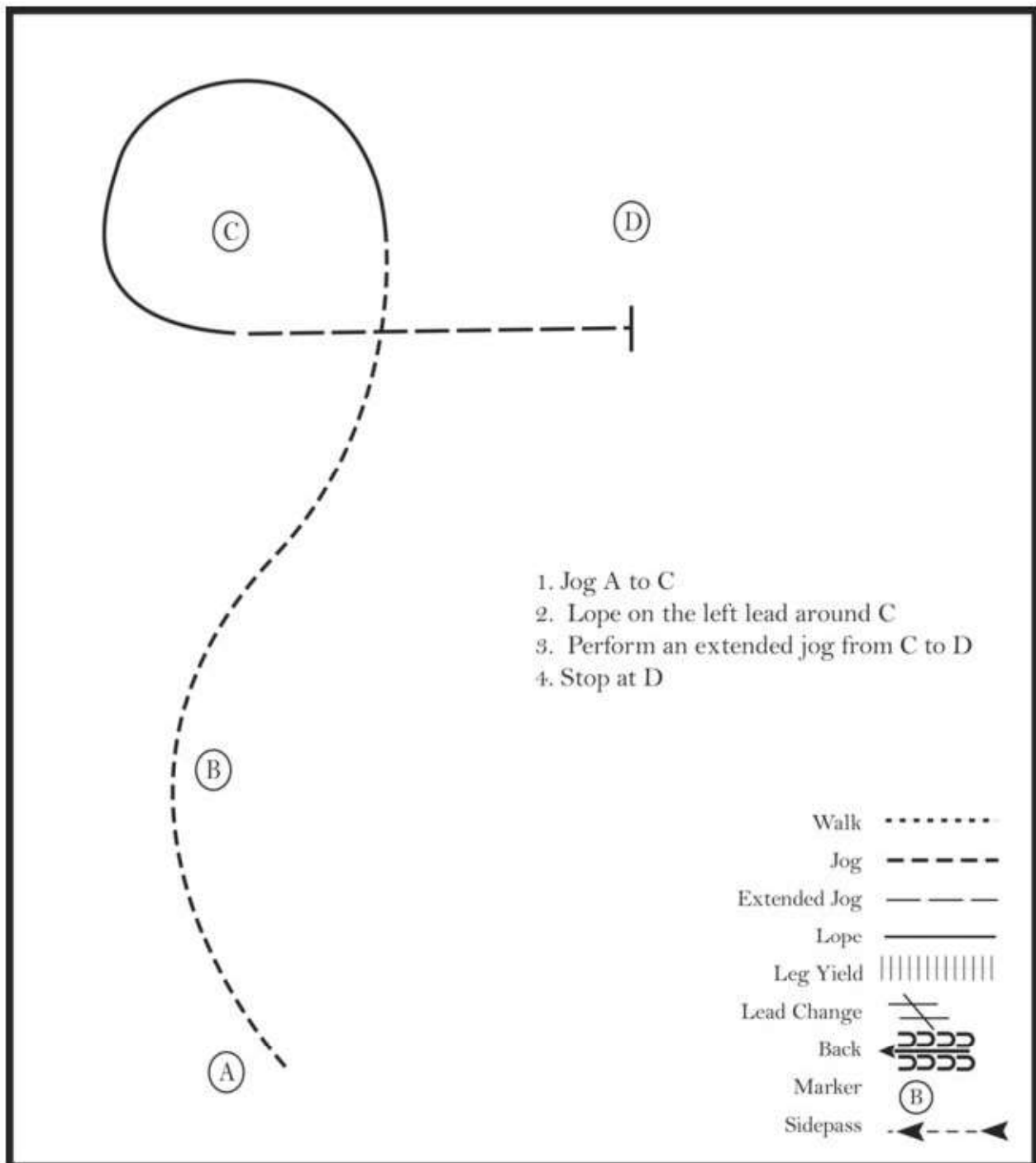

Pattern Provided by:

*Wyoming 4-H*

# Wyoming 4-H

## Wyoming 4-H Western Horsemanship (Junior) -6

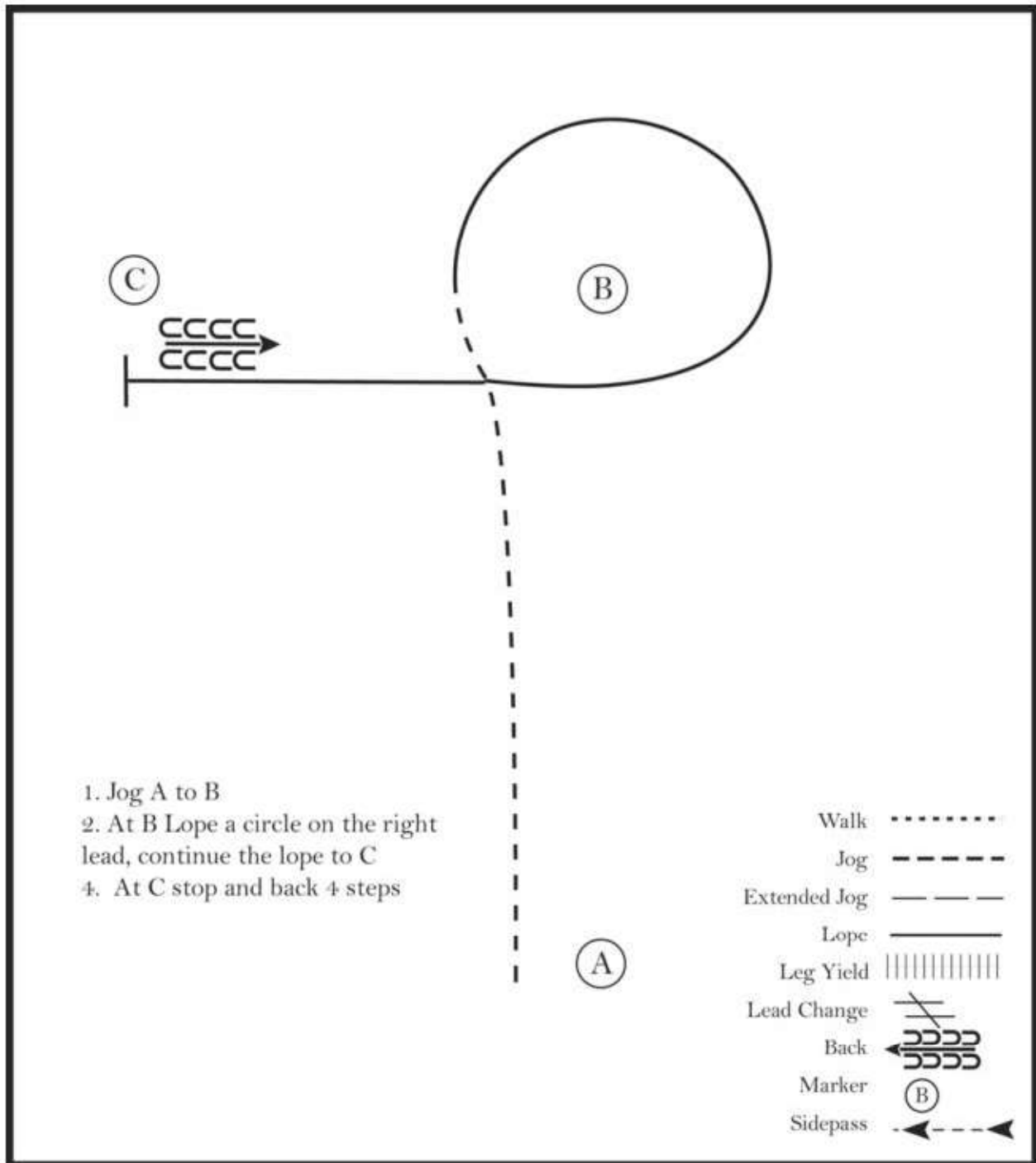

Pattern Provided by:

*Wyoming 4-H*

# Wyoming 4-H

## Wyoming 4-H Western Horsemanship (Senior) -1

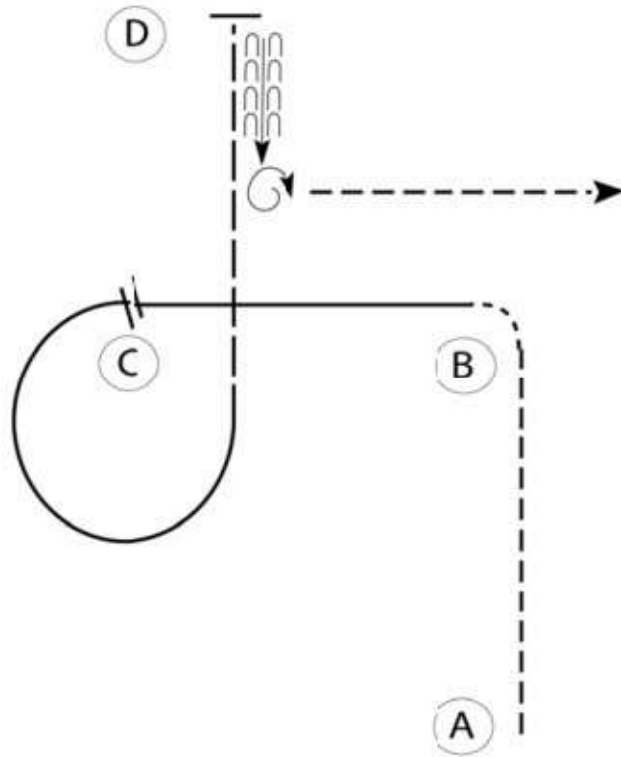

Be ready at A.

1. Jog to B.
2. Walk around B.
3. Lope on the right lead from B to C.
4. Perform a simple lead change at C.
5. Lope on the left lead around C.
6. Extended jog from C to D.
7. Stop at D and back approximately one horse length.
8. Spin 1 1/4 turns to the right on the hindquarters and jog out.

Walk	-----
Jog	-----
Extended Jog	- - - - -
Lope	—————
Lead Change	— / —
Back	← — — — —
Marker	ⓑ

Follow the directions of your ring steward.

**Pattern Provided by:**

*Wyoming 4-H*

# Wyoming 4-H

## Wyoming 4-H Western Horsemanship (Senior) -2

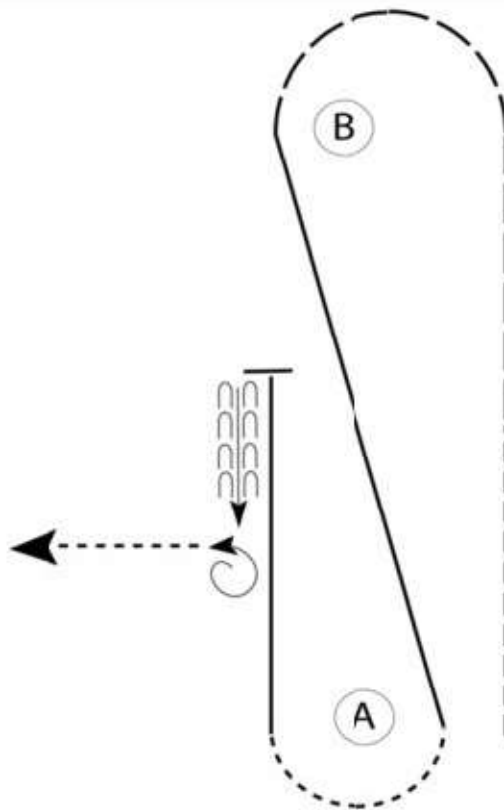

Be ready at A.

1. Jog halfway to B.
2. Extend the jog to and around B.
3. Lope on the left lead diagonally back to A.
4. Walk around A.
5. Lope on the right lead halfway to B.
6. Stop and back approximately two horse lengths.
7. Perform a 1 1/4 turn to the left.
8. Walk straight away.

Follow the instructions of your ring steward.

Walk	-----
Jog	-----
Extended Jog	-----
Lope	-----
Lead Change	
Back	
Marker	(B)

**Pattern Provided by:**

*Wyoming 4-H*

# Wyoming 4-H

## Wyoming 4-H Western Horsemanship (Senior) -3

Be ready before A.

1. Walk to A.
2. Jog to center of A and B.
3. Perform an extended jog through B, C and D as shown.
4. At top of pattern, begin left lead lope to between C and B.
5. Change leads between C and B.
6. Lope with SPEED to A.
7. Slow to lope at A and lope until even with B.
8. Stop at B and back approximately one horse length.
9. Perform a 1/4 turn left and jog away from pattern.

Follow the instructions of your ring steward.

Walk	.....
Jog	-----
Extended Jog	-----
Lope	—————
Lead Change	⚡
Back	←————
Marker	ⓑ

**Pattern Provided by:**

*Wyoming 4-H*

# Wyoming 4-H

## Wyoming 4-H Western Horsemanship (Senior) -4

Be ready at A.

1. Walk from A to center of pattern
2. Jog until even with B.
3. Lope a half circle on the right lead to and around B.
4. Perform a simple lead change in the center of the pattern.
5. Lope a half circle on the left lead to C.
6. Extend the jog until even with B.
7. Stop and back approximately one horse length.
8. Perform a 1/4 turn right and walk off.

Follow the directions of your ring steward.

Walk	-----
Jog	-----
Extended Jog	-----
Lope	-----
Lead Change	-----
Back	←-----
Marker	Ⓚ

**Pattern Provided by:**

*Wyoming 4-H*



# Wyoming 4-H

## Wyoming 4-H Western Horsemanship (Senior) -6

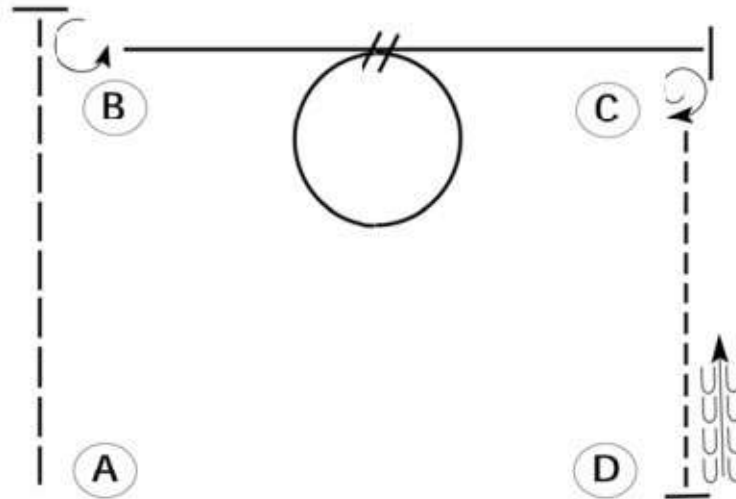

Be ready at A.

1. Extended trot from A past B.
2. Stop past B and perform a 270 degree turn to the left.
3. Lope on the left lead halfway to C.
4. Change leads and perform a small, slow circle to the right.
5. Continue to lope past C and stop.
6. Perform a 1 1/4 turn to the right.
7. Jog to D.
8. Stop and back approximately one horse length.

Follow the instructions of your ring steward.

Walk	-----
Jog	-----
Extended Jog	-----
Lope	-----
Lead Change	-----
Back	←-----
Marker	⊙ B

**Pattern Provided by:**

*Wyoming 4-H*



# Wyoming 4-H

## Wyoming 4-H Western Riding (Junior/Intermediate)

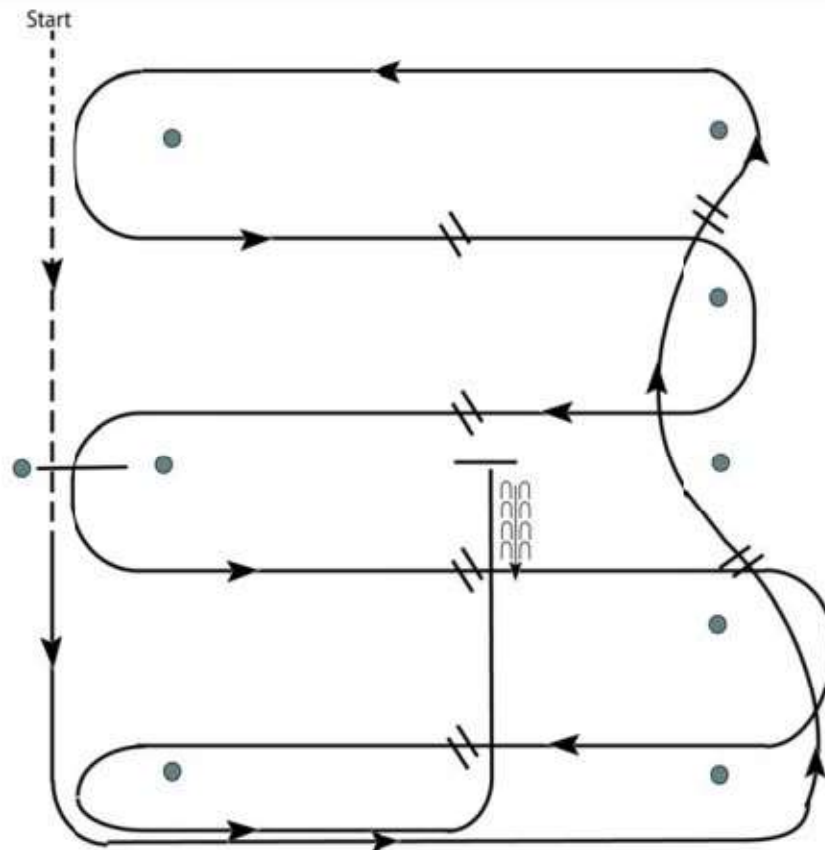

1. Walk at least 15' & jog over log.
2. Transition to left lead and lope around end.
3. First line change.
4. Second line change. Lope around end of arena
5. First crossing change.
6. Second crossing change.
7. Lope over log.
8. Third crossing change.
9. Fourth crossing change.
10. Lope up the center, stop and back.

**Pattern Provided by:**

*Wyoming 4-H*



# Wyoming 4-H

## Wyoming 4-H Trail (Intermediate) -1

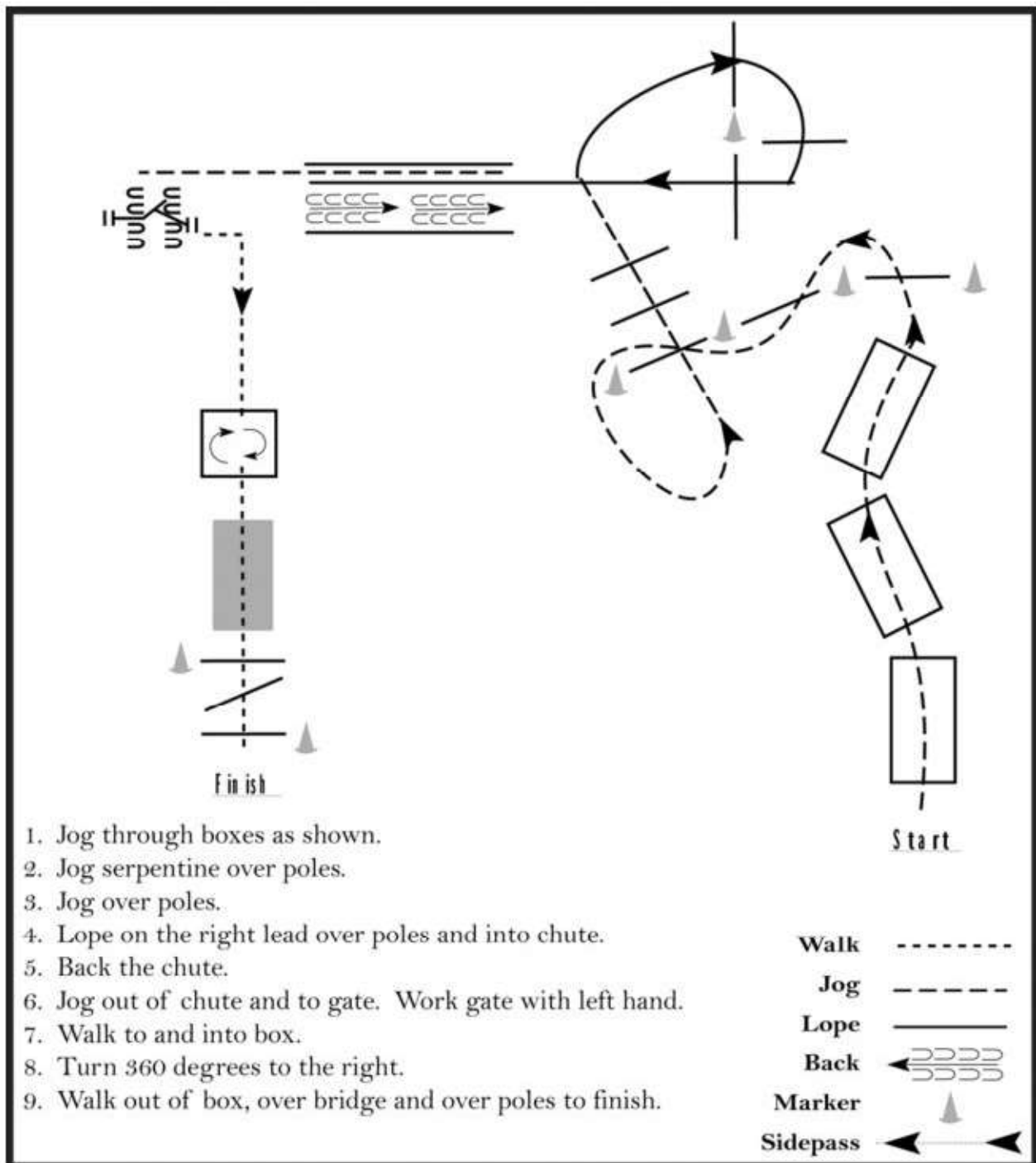

**Pattern Provided by:**

*Wyoming 4-H*



# Wyoming 4-H

## Wyoming 4-H Trail (Intermediate) -3

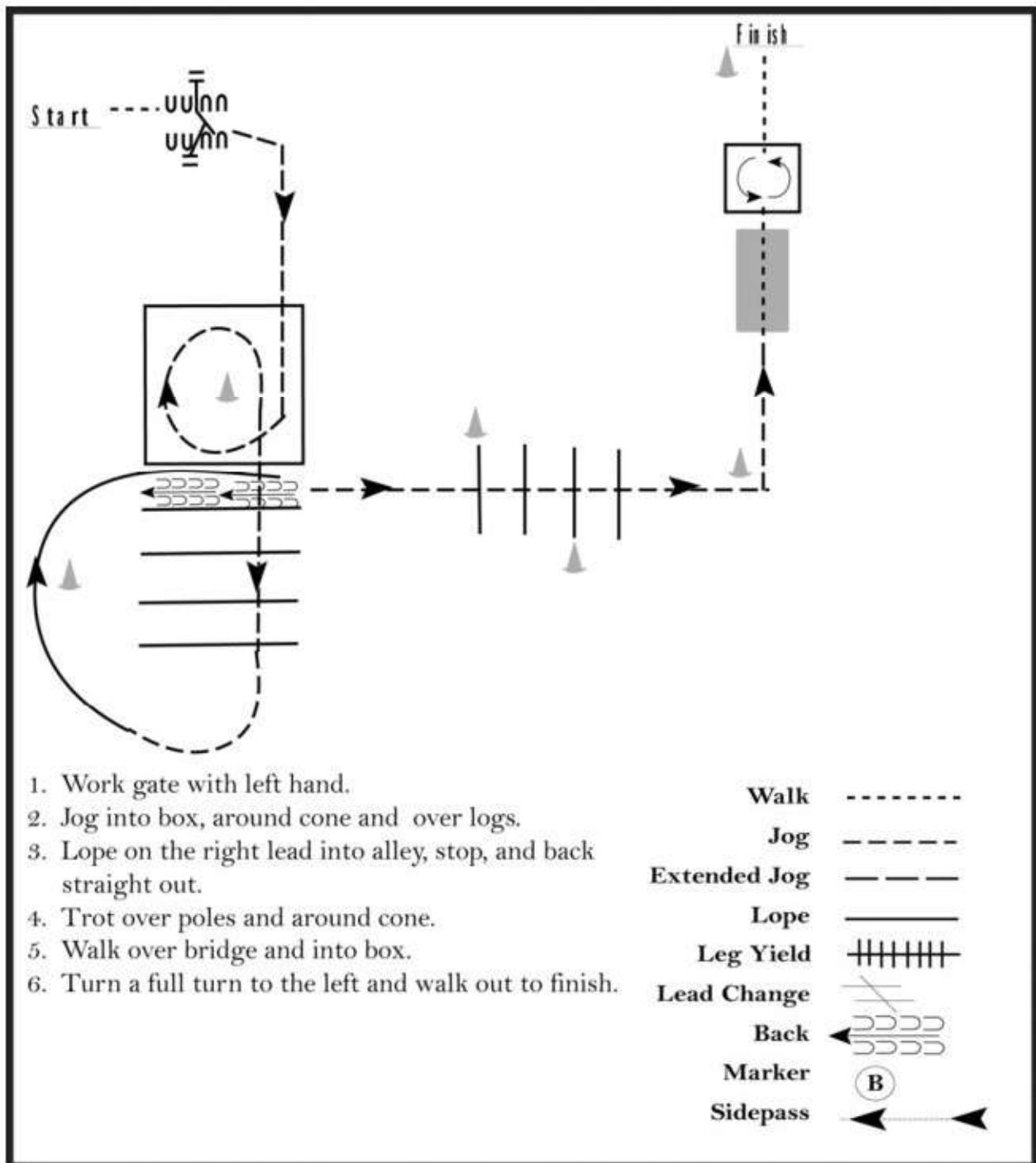

Pattern Provided by:

*Wyoming 4-H*

# Wyoming 4-H

## Wyoming 4-H Trail (Intermediate) -4

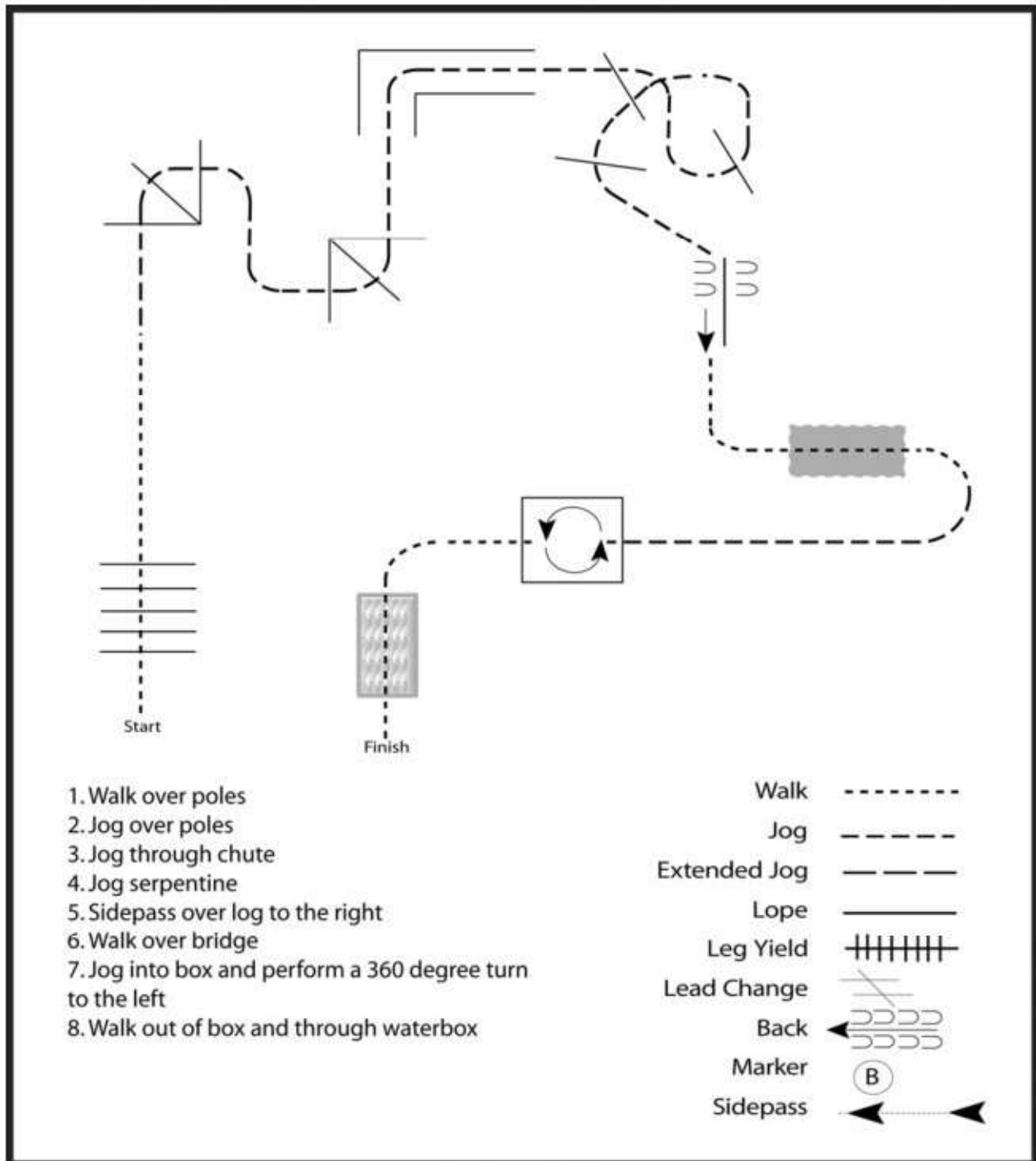

Updated 7/13

Pattern Provided by:

*Wyoming 4-H*

# Wyoming 4-H

## Wyoming 4-H Trail (Intermediate) -5

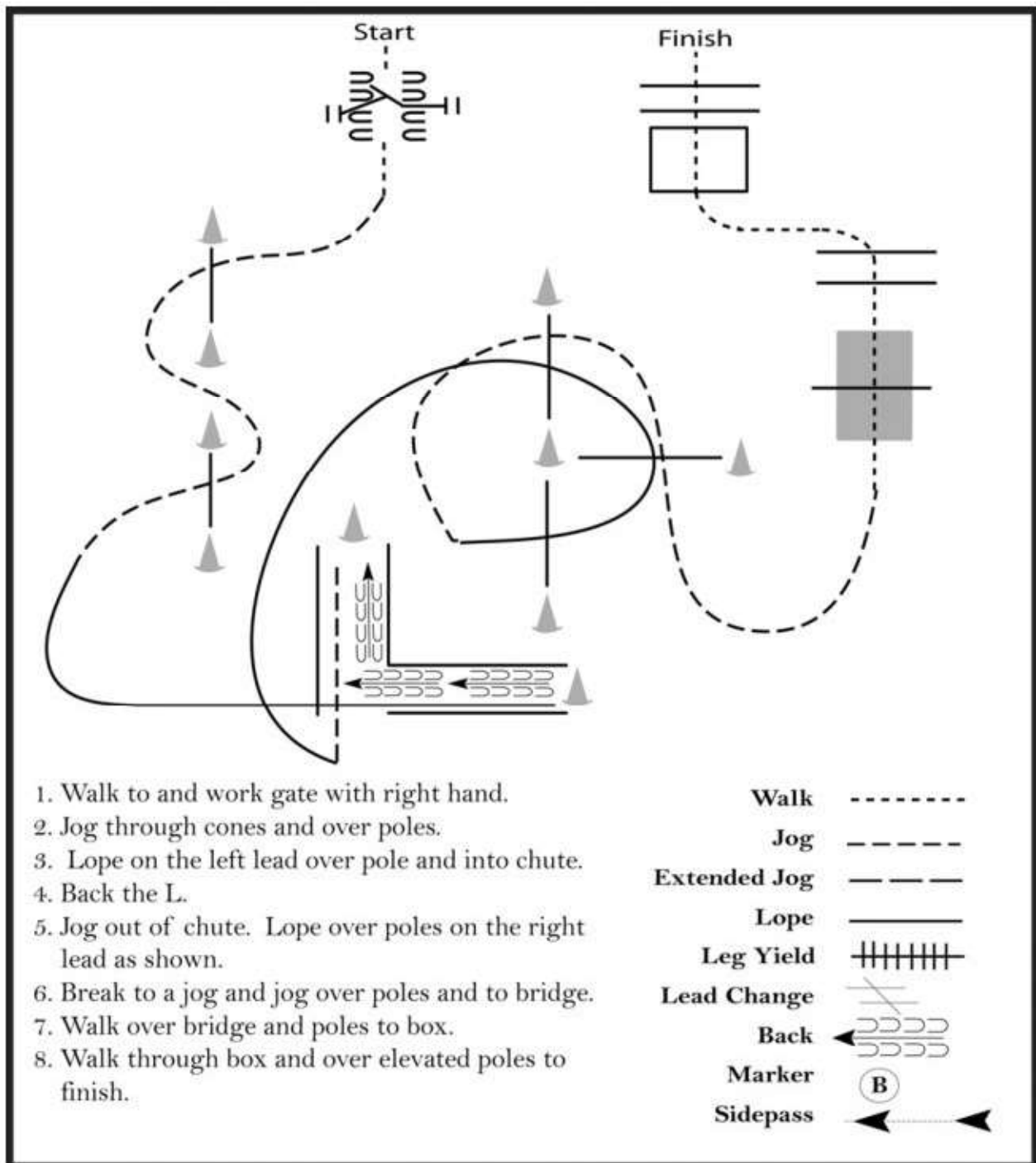

Pattern Provided by:

*Wyoming 4-H*

# Wyoming 4-H

## Wyoming 4-H Trail (Intermediate) -6

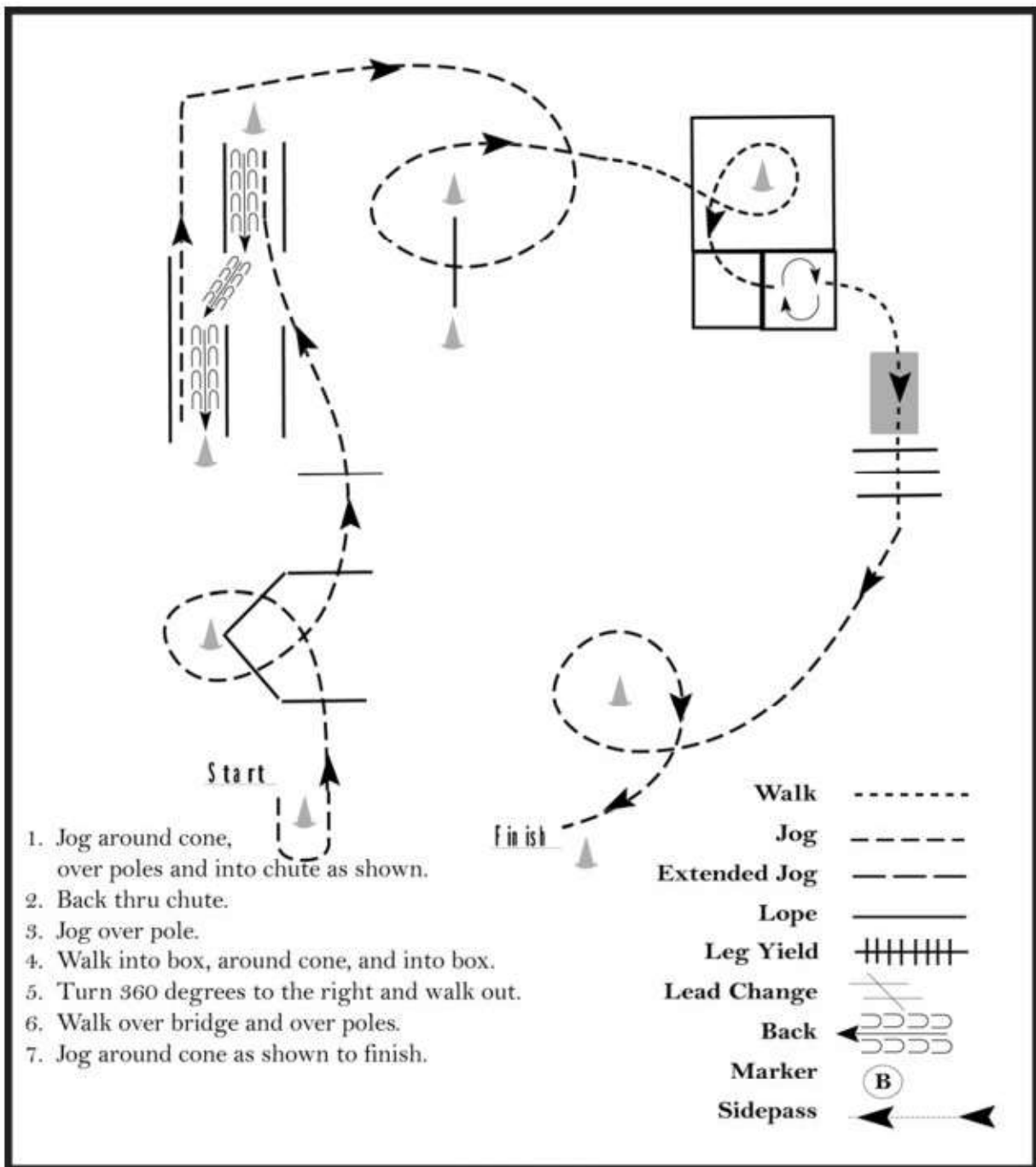

Updated 7/13

Pattern Provided by:

*Wyoming 4-H*



# Wyoming 4-H

## Wyoming 4-H Trail (Junior) -2

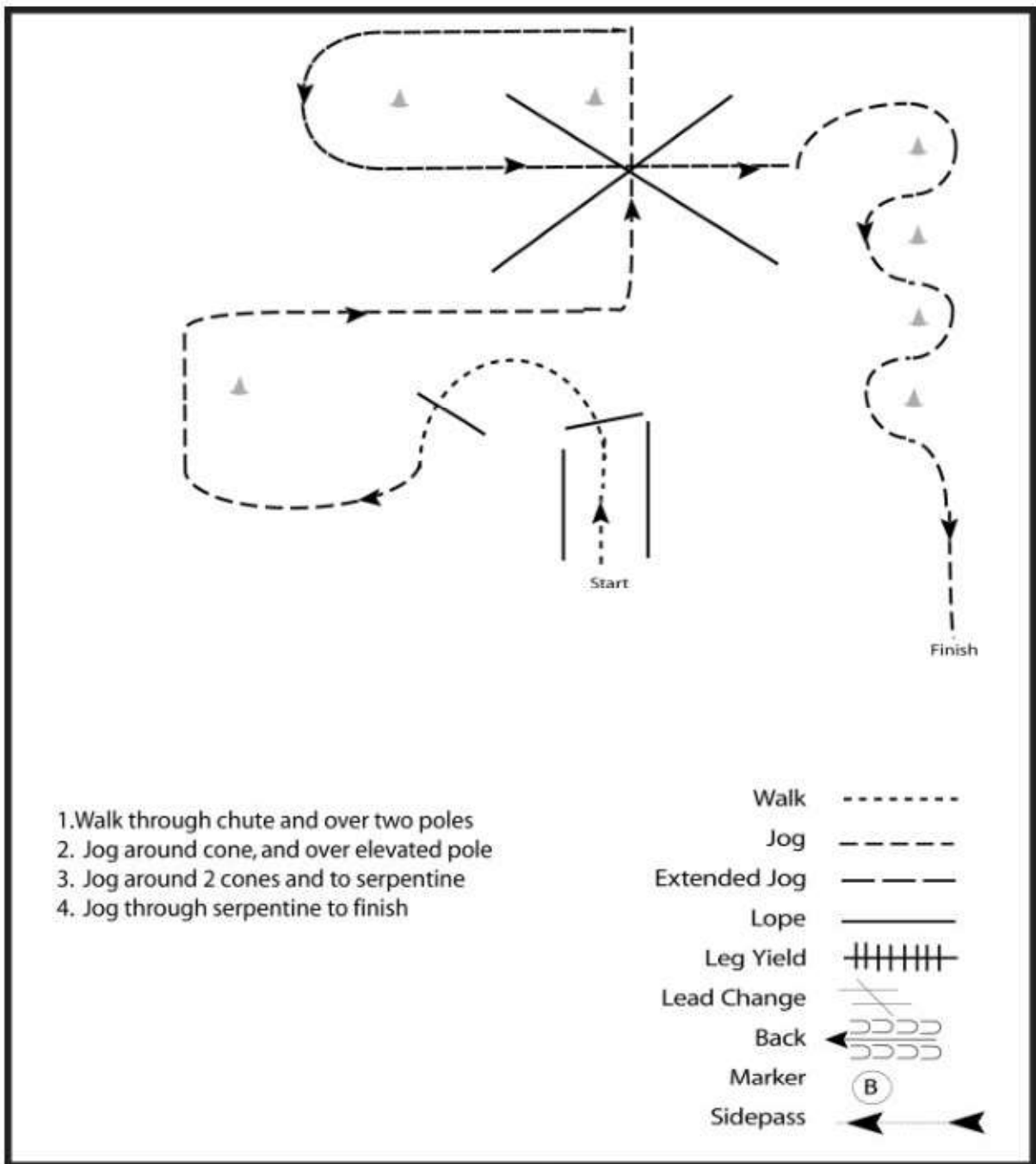

Updated 7/13

Pattern Provided by:

*Wyoming 4-H*

# Wyoming 4-H

## Wyoming 4-H Trail (Junior) -3

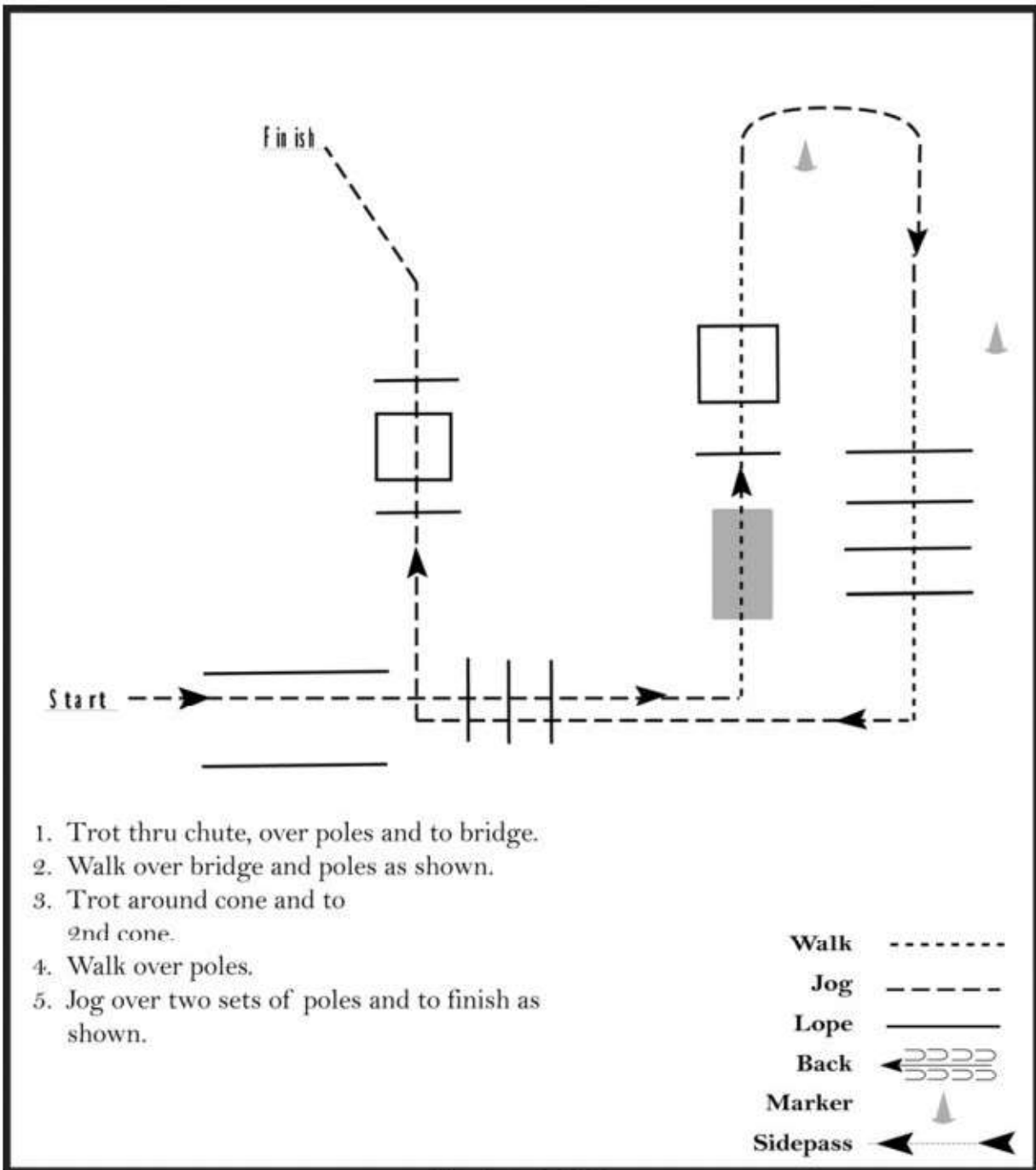

Updated 7/13

Pattern Provided by:

*Wyoming 4-H*

# Wyoming 4-H

## Wyoming 4-H Trail (Junior) -4

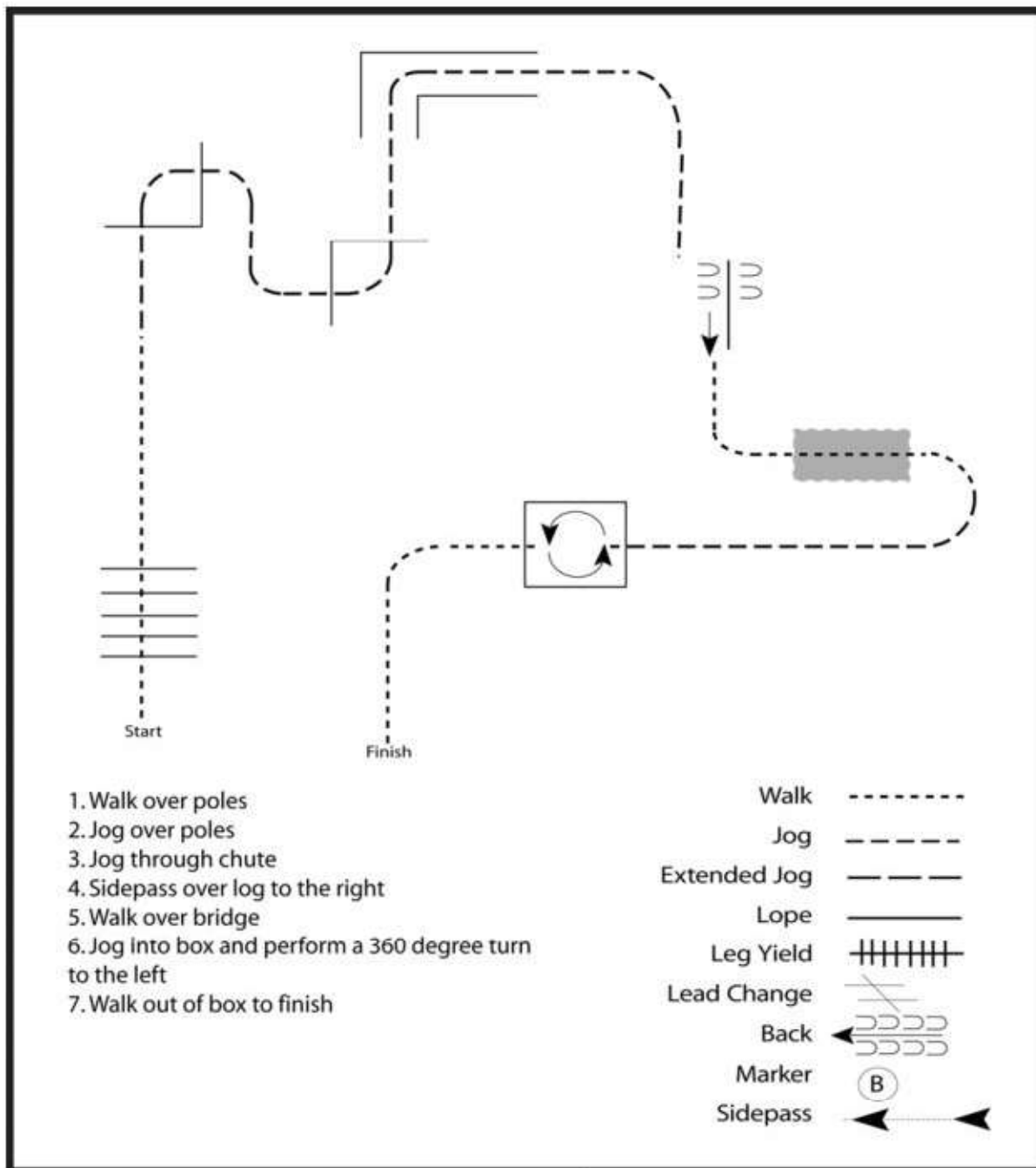

Updated 7/13

Pattern Provided by:

*Wyoming 4-H*

# Wyoming 4-H

## Wyoming 4-H Trail (Junior) -5

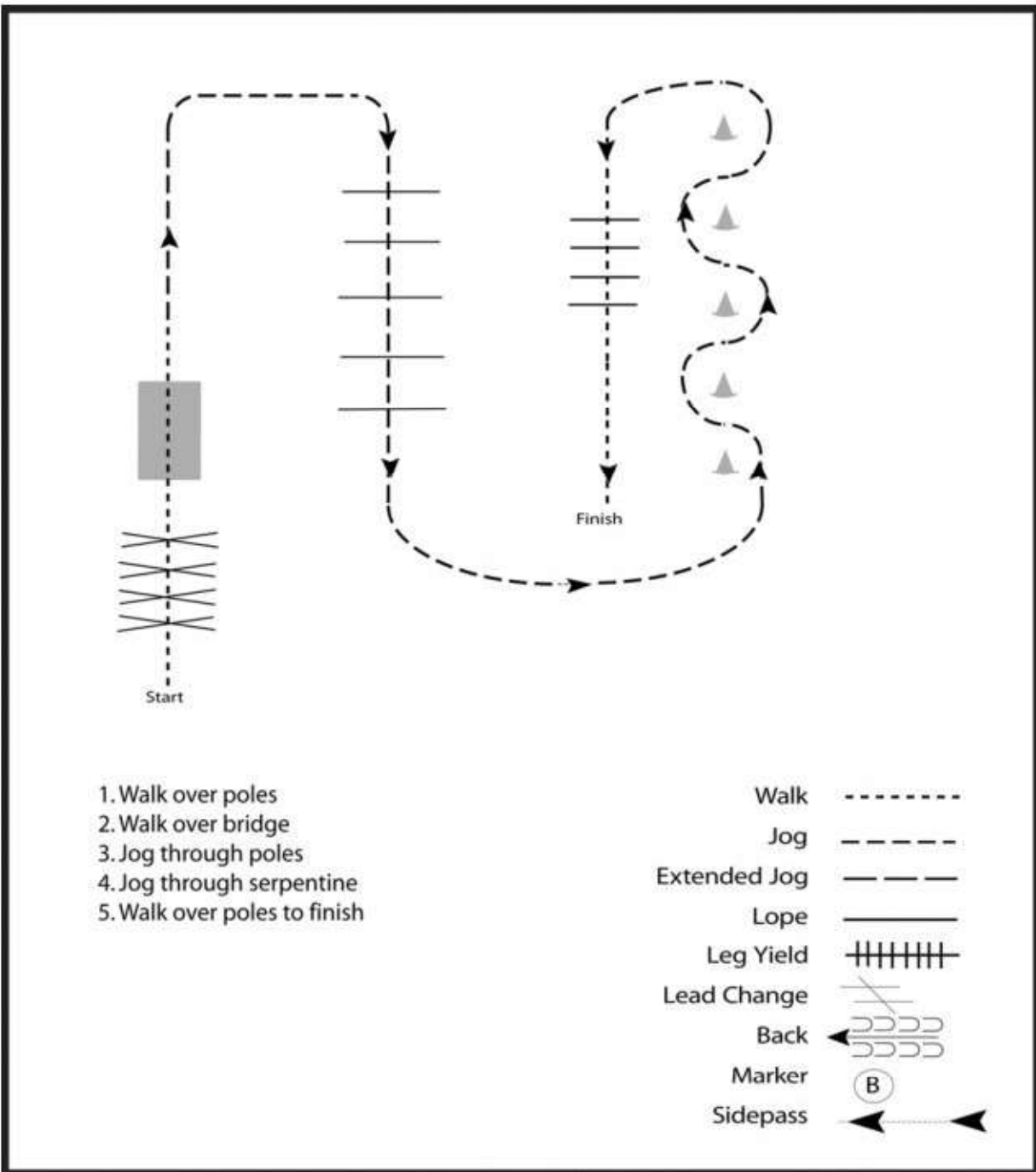

Updated 7/13

Pattern Provided by:

*Wyoming 4-H*

# Wyoming 4-H

## Wyoming 4-H Trail (Junior) -6

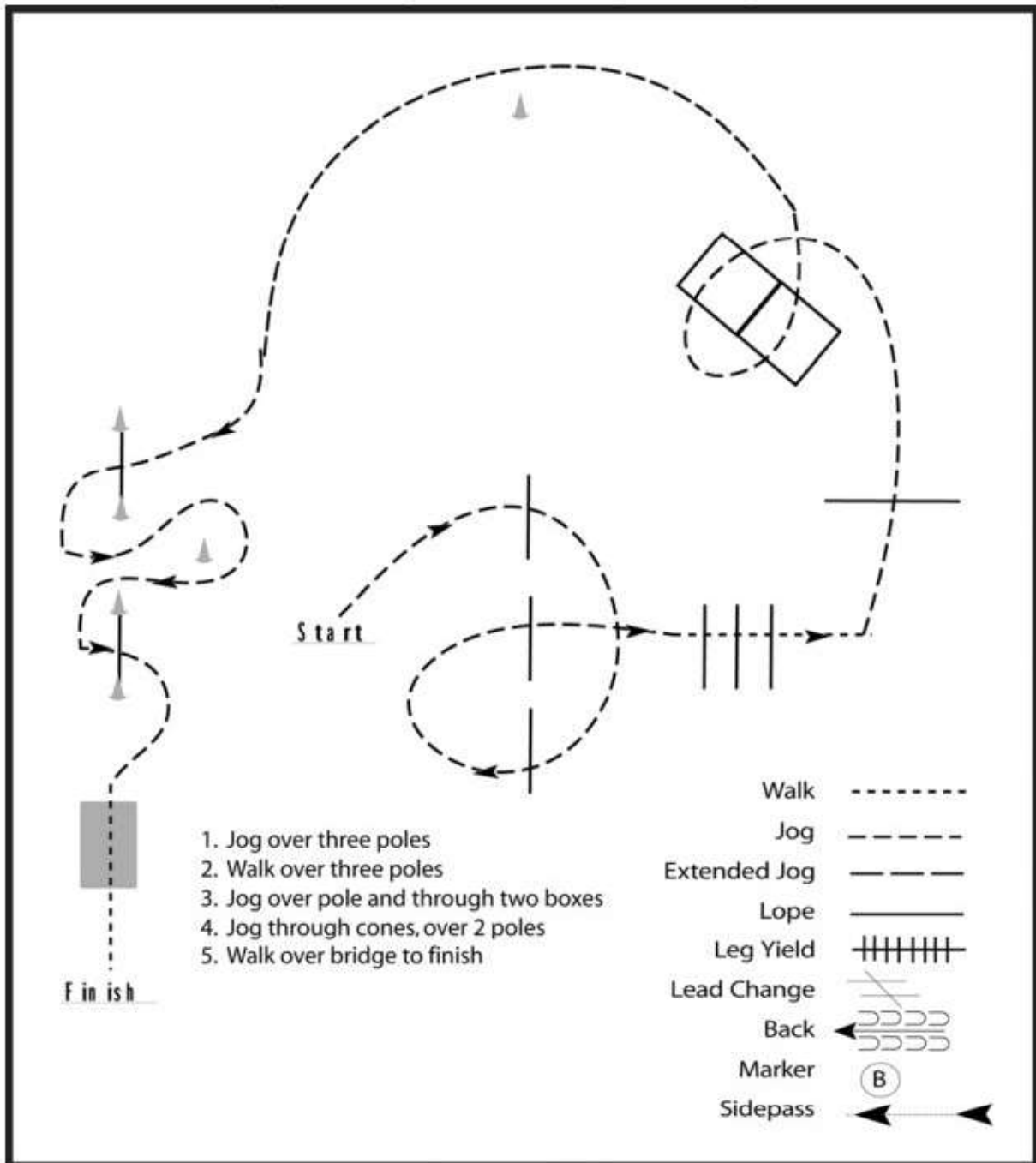

Updated 7/13

Pattern Provided by:

*Wyoming 4-H*

# Wyoming 4-H

## Wyoming 4-H Trail (Senior) -1

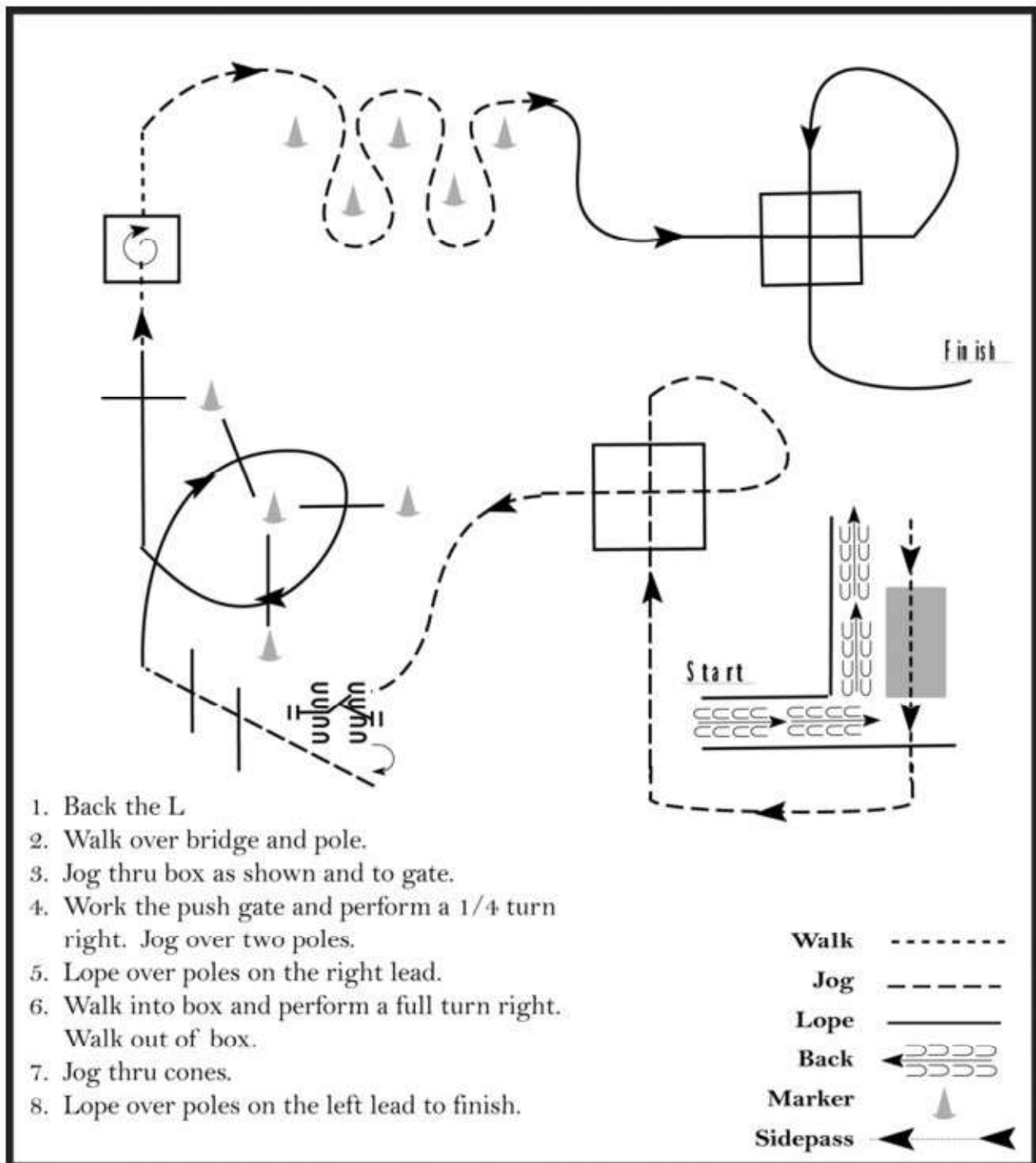

Pattern Provided by:

*Wyoming 4-H*

# Wyoming 4-H

## Wyoming 4-H Trail (Senior) -2

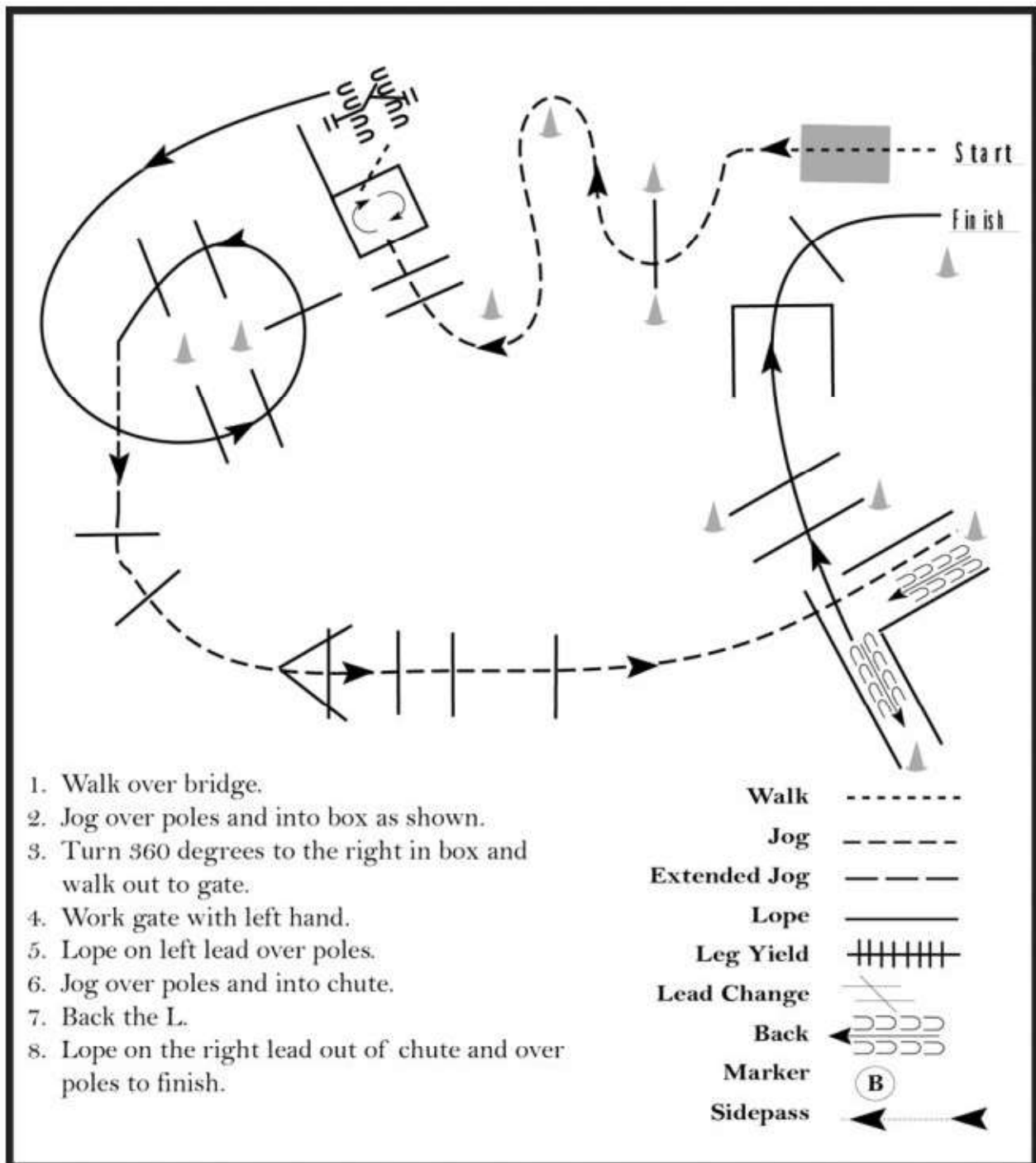

Pattern Provided by:

*Wyoming 4-H*

# Wyoming 4-H

## Wyoming 4-H Trail (Senior) -3

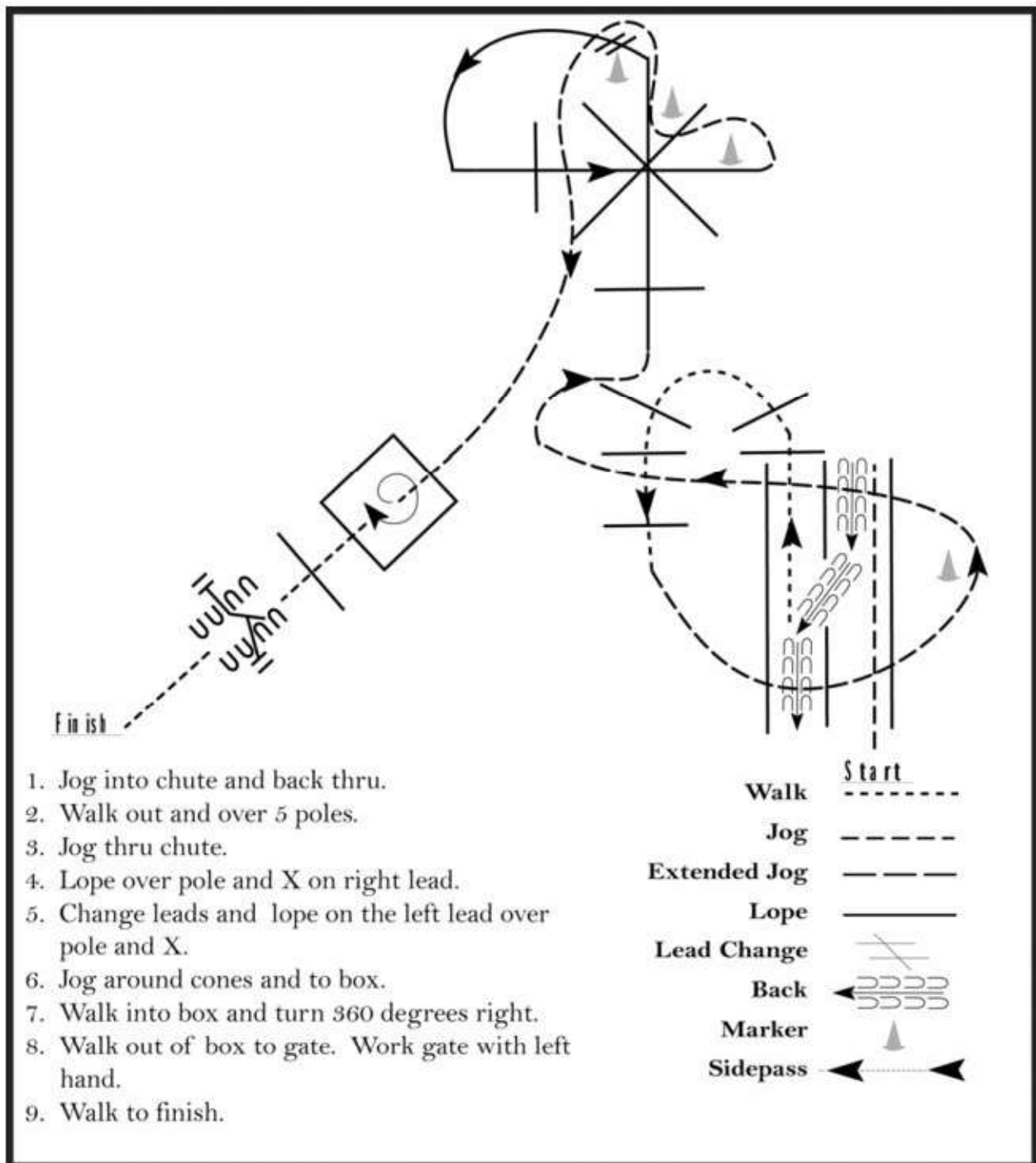

Pattern Provided by:

*Wyoming 4-H*

# Wyoming 4-H

## Wyoming 4-H Trail (Senior) -4

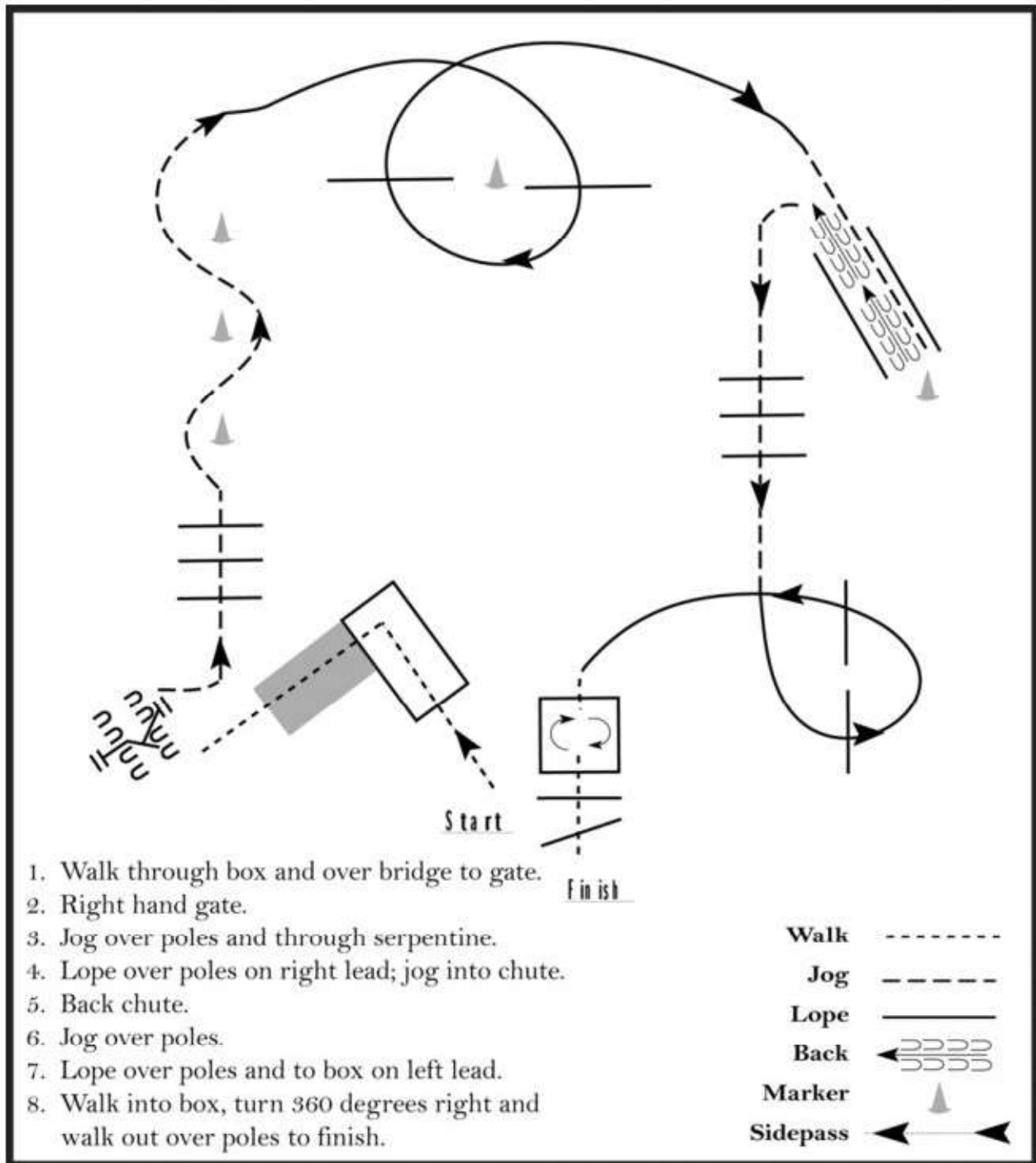

**Pattern Provided by:**

*Wyoming 4-H*

# Wyoming 4-H

## Wyoming 4-H Trail (Senior) -5

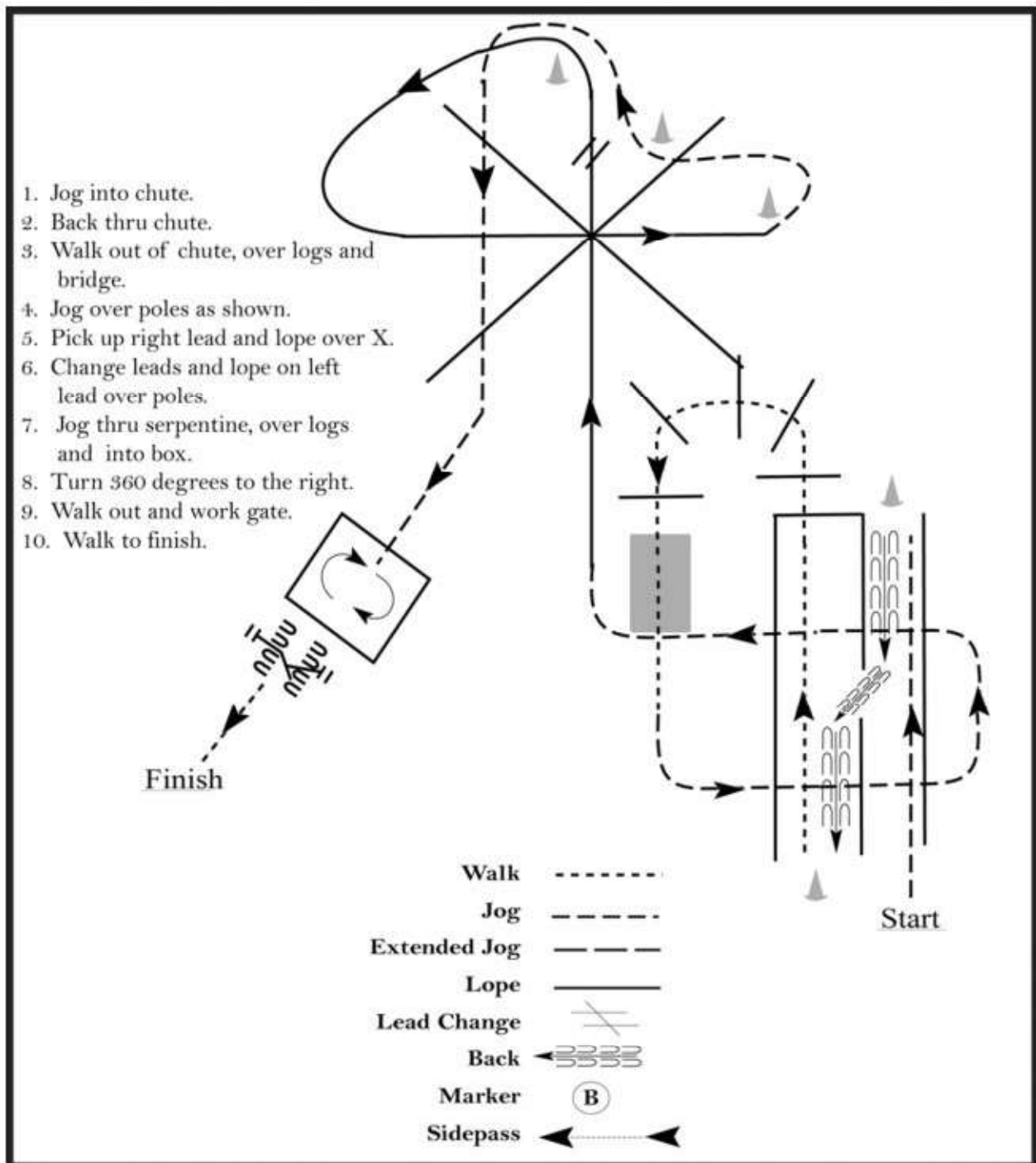

Pattern Provided by:

*Wyoming 4-H*

# Wyoming 4-H

## Wyoming 4-H Trail (Senior) -6

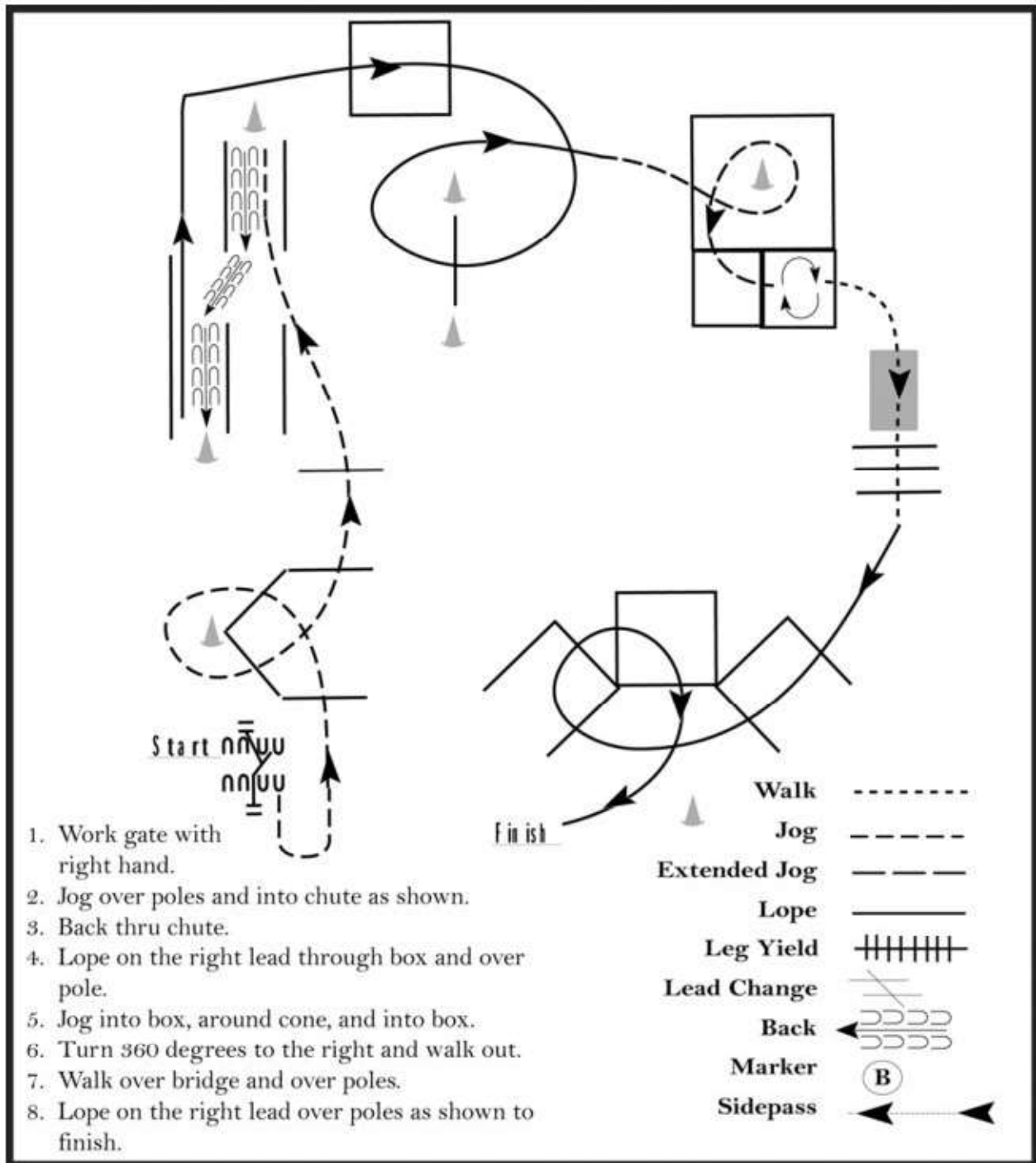

Pattern Provided by:

*Wyoming 4-H*

# Wyoming 4-H

## Wyoming 4-H Trail (Senior) -7

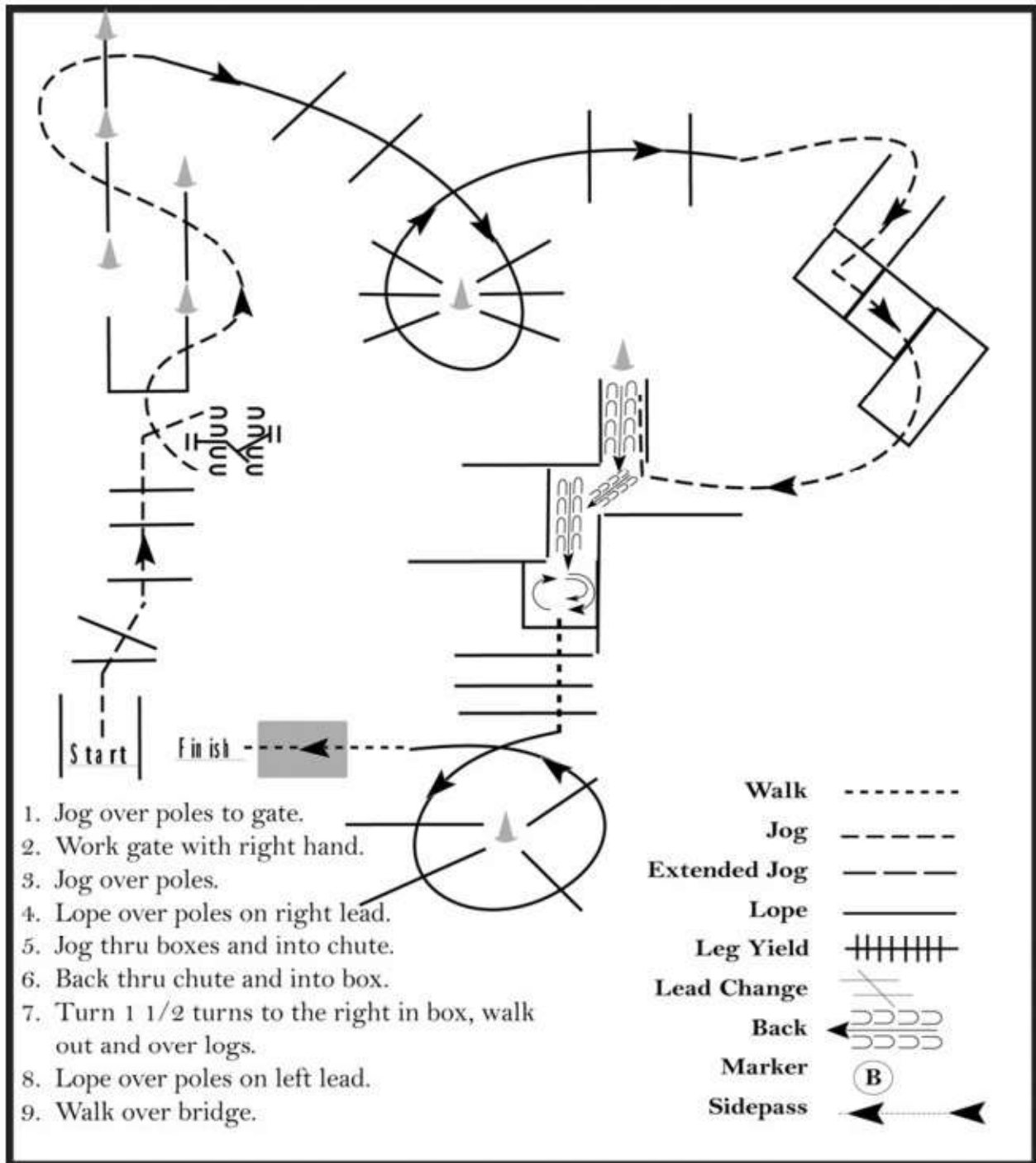

Pattern Provided by:

*Wyoming 4-H*

# Wyoming 4-H

## Wyoming 4-H Reining Pattern (Intermediate) – 3

Ride the pattern as follows:

1. Run with speed past the center marker and perform a sliding stop.
2. Back to the center of the arena or back at least 10 feet.
3. Hesitate.
4. Complete three spins to the right.
5. Hesitate.
6. Complete three and one-quarter spins to the left. After completion, the horse should be facing the left wall of the arena.
7. Hesitate.
8. Beginning in the left lead, complete two circles to the left: the first circle should be small and performed at a slow speed; the second circle should be large and performed at a fast speed.
9. Change the lead at the center of the arena.
10. Complete two circles to the right: the first circle should be small and performed at a slow speed; the second circle should be large and performed at a fast speed.
11. Change the lead at the center of the arena.
12. Begin a large circle to the left at a fast speed but do not close the circle. Run up the right side of the arena past the center marker and perform a right rollback.
13. Without hesitating, continue back around the previous circle but do not close the circle. Run up the left side of the arena past the center marker and perform a left rollback.
14. Without hesitating, continue back around the previous circle but do not close the circle. Run up the right side of the arena past the center marker and perform a sliding stop.
15. Hesitate.
16. Ride to the judge for inspection.

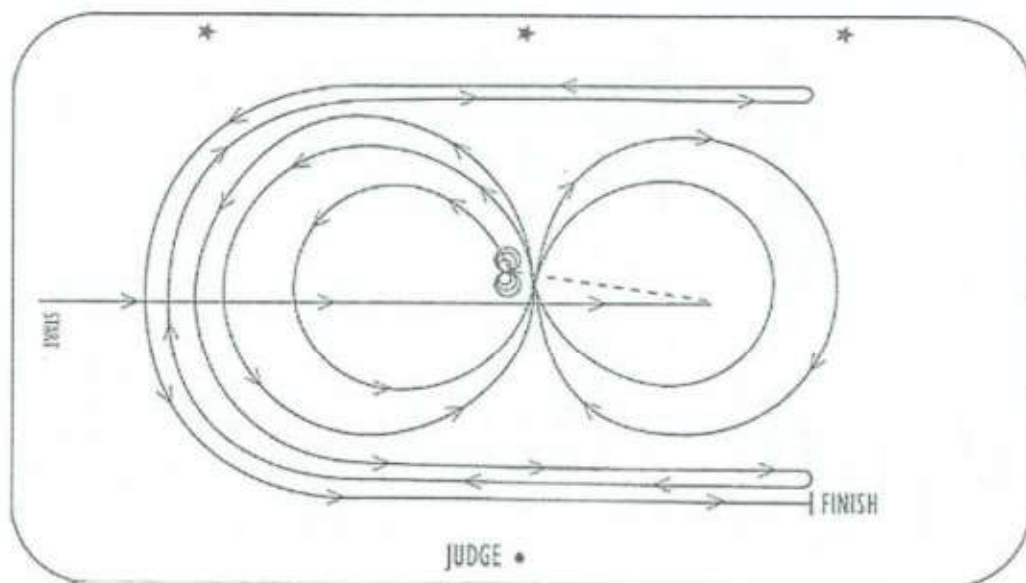

Pattern Provided by: *Wyoming 4-H*



# Wyoming 4-H

## Wyoming 4-H Reining Pattern (Intermediate) – 2

Ride the pattern as follows:

1. Run with speed to the far end of the arena past the end marker and perform a left rollback without hesitation.
2. Run with speed to the opposite end of the arena past the end marker and perform a right rollback without hesitation.
3. Run past the center marker and perform a sliding stop. Back to the center of the arena or back at least 10 feet.
4. Complete two spins to the right.
5. Hesitate.
6. Complete two and one-quarter spins to the left. After completion, the horse should be facing the left wall of the arena.
7. Hesitate.
8. Beginning on the left lead, complete one small circle at a slow speed.
9. Change lead at the center of the arena.
10. Complete one large circle at a fast speed.
11. Change lead at the center of the arena.
12. Begin a large circle at a fast speed to the left but do not close the circle.
13. Run straight up the side of the arena past the center marker and perform a sliding stop.
14. Hesitate.
15. Ride to the judge for inspection.

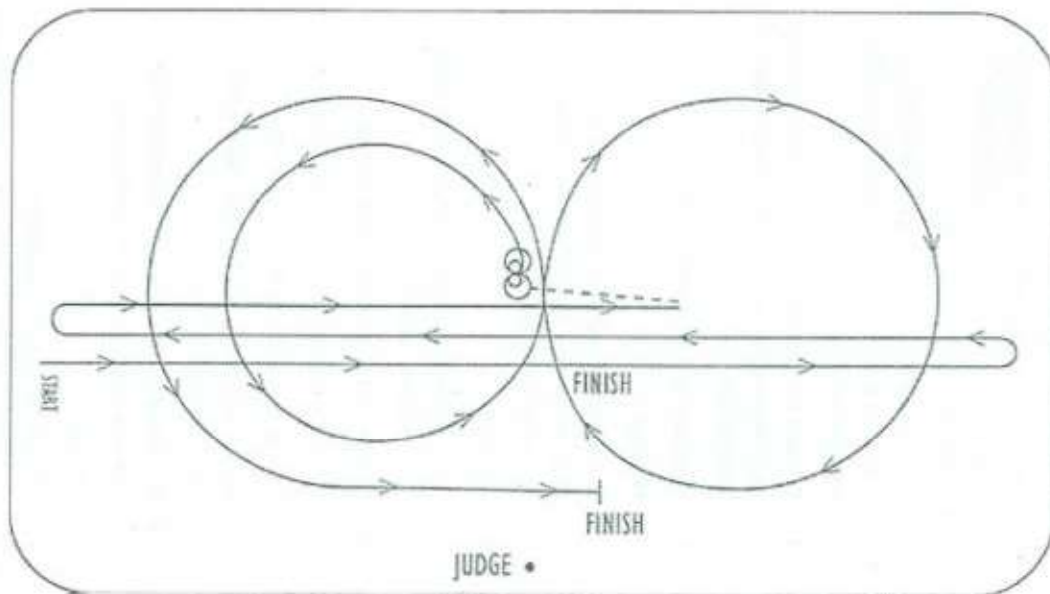

Pattern Provided by: *Wyoming 4-H*

# Wyoming 4-H

## Wyoming 4-H Reining Pattern (Intermediate) – 3

Ride the pattern as follows:

1. Run with speed past the center marker and perform a sliding stop.
2. Back to the center of the arena or back at least 10 feet.
3. Hesitate.
4. Complete three spins to the right.
5. Hesitate.
6. Complete three and one-quarter spins to the left. After completion, the horse should be facing the left wall of the arena.
7. Hesitate.
8. Beginning in the left lead, complete two circles to the left: the first circle should be small and performed at a slow speed; the second circle should be large and performed at a fast speed.
9. Change the lead at the center of the arena.
10. Complete two circles to the right: the first circle should be small and performed at a slow speed; the second circle should be large and performed at a fast speed.
11. Change the lead at the center of the arena.
12. Begin a large circle to the left at a fast speed but do not close the circle. Run up the right side of the arena past the center marker and perform a right rollback.
13. Without hesitating, continue back around the previous circle but do not close the circle. Run up the left side of the arena past the center marker and perform a left rollback.
14. Without hesitating, continue back around the previous circle but do not close the circle. Run up the right side of the arena past the center marker and perform a sliding stop.
15. Hesitate.
16. Ride to the judge for inspection.

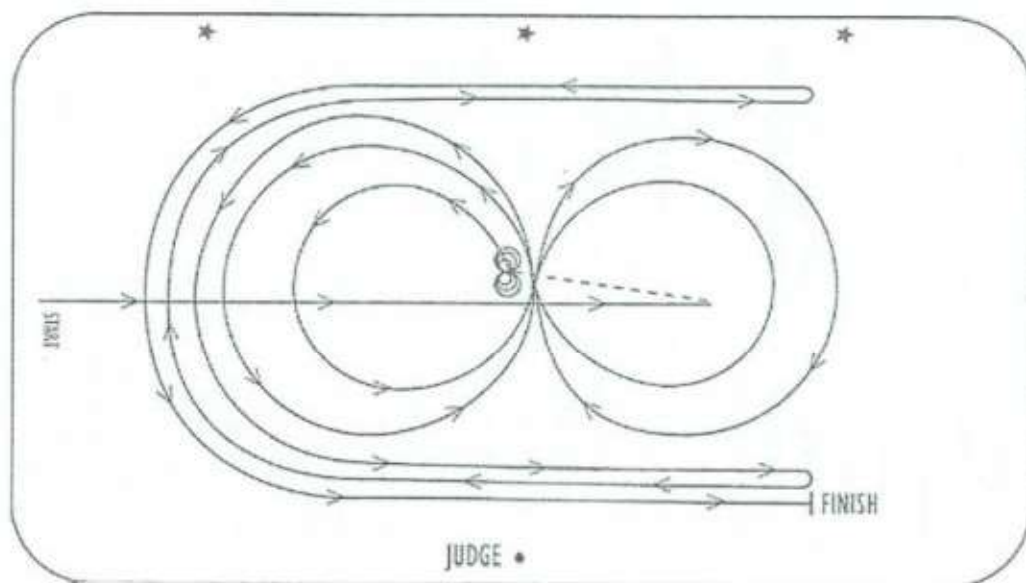

Pattern Provided by: *Wyoming 4-H*

# Wyoming 4-H

## Wyoming 4-H Reining Pattern (Junior) – 2

The arena or plot should be approximately 50 feet by 150 feet.

The ride pattern follows:

Enter the arena and approach starting position.

1. Run with speed past the center marker.
2. Stop and back up the center of the pattern.
3. Settle the horse for approximately ten seconds.
4. Start the lope. The circles should be made inside the end markers.
5. Ride two circles to the right: the first circle should be small and ridden at a slow speed; the second circle should be large and ridden at a fast speed.
6. Ride two circles to the left: the first circle should be small and ridden at a slow speed; the second circle should be large and ridden at a fast speed.
7. Perform a left rollback beyond the far end marker.
8. Perform a right rollback beyond the entry end marker.
9. Stop past the center marker.
10. Let the horse settle; then in the approximate area of the stop do the spins.
11. 360-degree spin to the right or to the left.
12. 360-degree spin to the left or to the right, opposite of number 11.
13. Walk to the judge and stop for inspection until dismissed.
14. The bridle may be dropped at the judge's discretion.

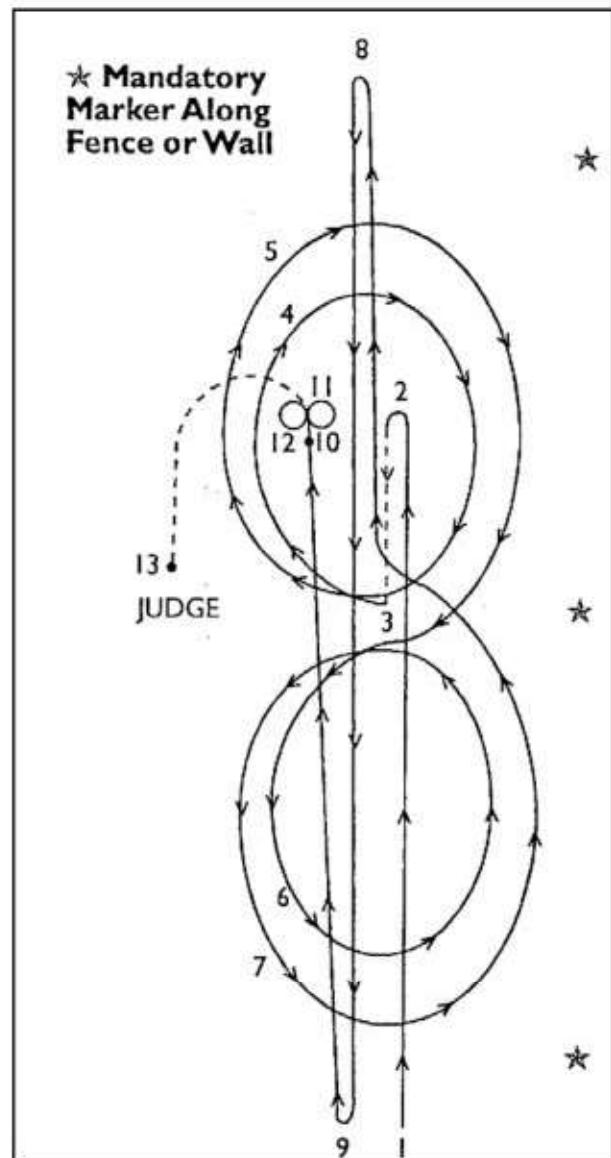

Pattern Provided by: *Wyoming 4-H*

# Wyoming 4-H

## Wyoming 4-H Reining Pattern (Junior) – 1

The ride pattern follows:

- S. Start - run with speed.
1. Stop - pivot to right and run with speed.
2. Stop - pivot to left and run.
3. Sliding stop.
4. Quarter turn to left.
5. Begin slow circle to the left in correct lead.
6. Ride circle to right with speed in correct lead.
7. Sliding stop - settle horse.
8. Back.
9. Ride to judge for inspection.

A bridle may be dropped at a judge's discretion.

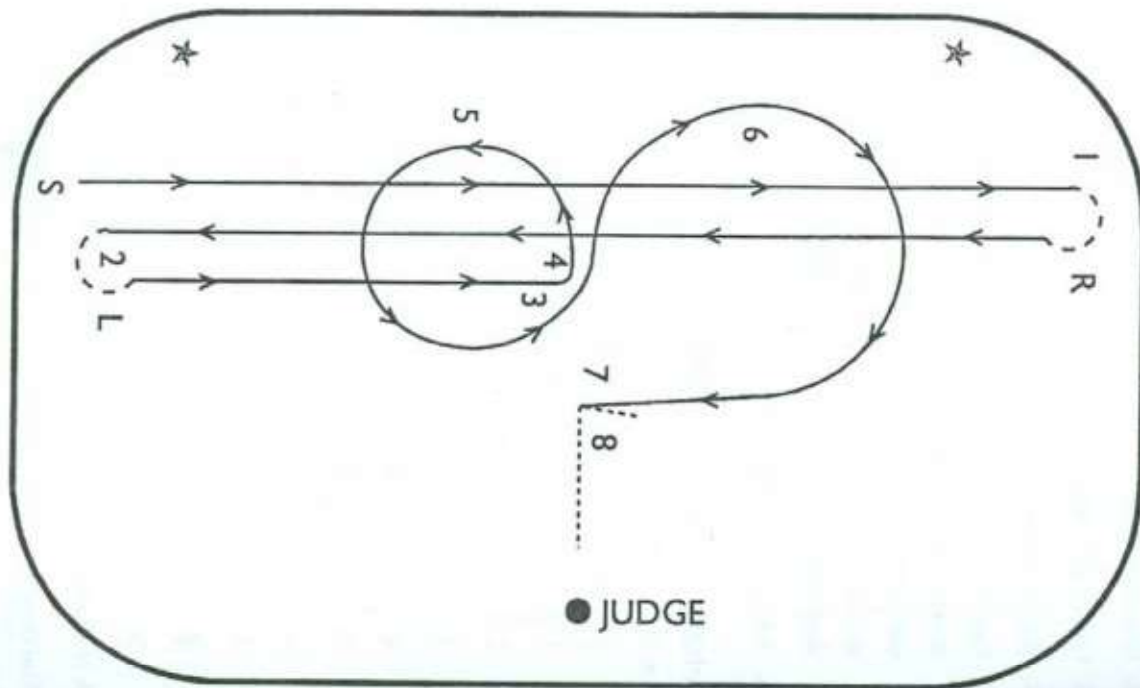

Pattern Provided by: *Wyoming 4-H*

# Wyoming 4-H

## Wyoming 4-H Reining Pattern (Junior) – 2

The arena or plot should be approximately 50 feet by 150 feet.

The ride pattern follows:

Enter the arena and approach starting position.

1. Run with speed past the center marker.
2. Stop and back up the center of the pattern.
3. Settle the horse for approximately ten seconds.
4. Start the lope. The circles should be made inside the end markers.
5. Ride two circles to the right: the first circle should be small and ridden at a slow speed; the second circle should be large and ridden at a fast speed.
6. Ride two circles to the left: the first circle should be small and ridden at a slow speed; the second circle should be large and ridden at a fast speed.
7. Perform a left rollback beyond the far end marker.
8. Perform a right rollback beyond the entry end marker.
9. Stop past the center marker.
10. Let the horse settle; then in the approximate area of the stop do the spins.
11. 360-degree spin to the right or to the left.
12. 360-degree spin to the left or to the right, opposite of number 11.
13. Walk to the judge and stop for inspection until dismissed.
14. The bridle may be dropped at the judge's discretion.

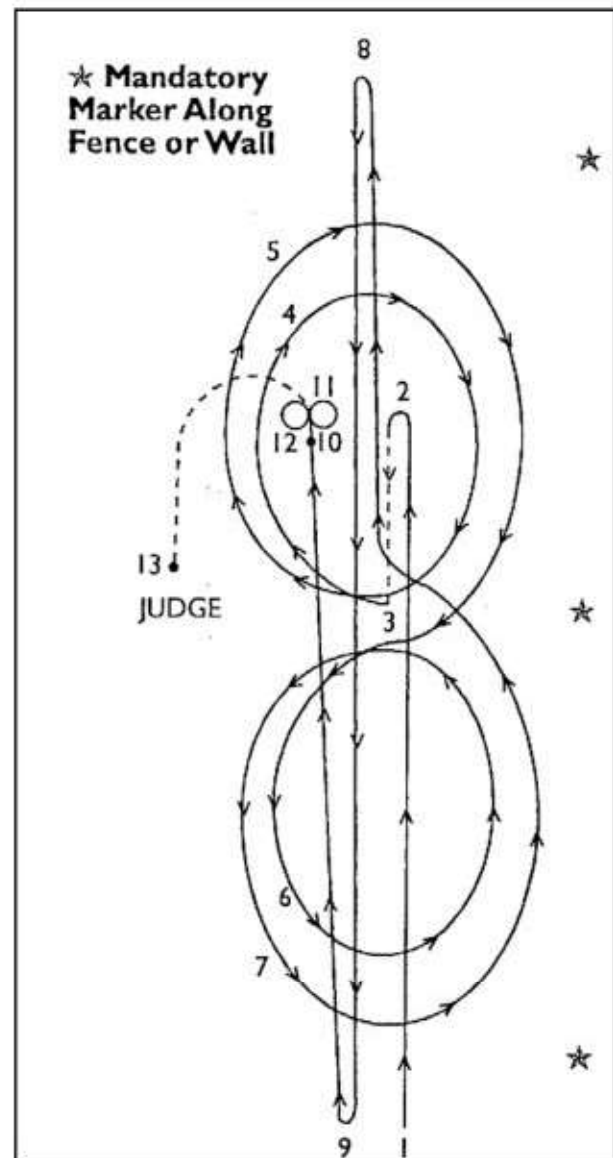

Pattern Provided by: *Wyoming 4-H*

# Wyoming 4-H

## Wyoming 4-H Reining Pattern (Senior) – 1

Ride the pattern as follows:

1. Start the pattern at the center of the arena by facing the left wall.
2. Beginning in the left lead, complete three circles to the left: the first circle should be small and performed at a slow speed; the second circle should be large and performed at a fast speed; the third circle should be small and performed at a slow speed.
3. Stop at the center of the arena.
4. Complete four spins to the left.
5. Hesitate.
6. Beginning in the right lead, complete three circles to the right: the first circle should be small and performed at a slow speed; the second circle should be large and performed at a fast speed; the third circle should be small and performed at a slow speed.
7. Stop at the center of the arena.
8. Complete four spins to the right.
9. Hesitate.
10. Beginning in the right lead, complete a large circle to the right at a fast speed. Then change the lead at the center of the arena and complete a large circle to the left at a fast speed.
11. Change the lead at the center of the arena and continue around the previous circle to the right but do not close the circle. Run down the right side of the arena past the center marker and perform a left rollback.
12. Without hesitating, continue around the previous circle but do not close the circle. Run down the left side of the arena past the center marker and perform a right rollback.
13. Without hesitating, continue back around the previous circle but do not close the circle. Run down the right side of the arena past the center marker and perform a sliding stop.
14. Hesitate.
15. Back at least 10 feet.
16. Hesitate.
17. Ride to the judge for inspection.

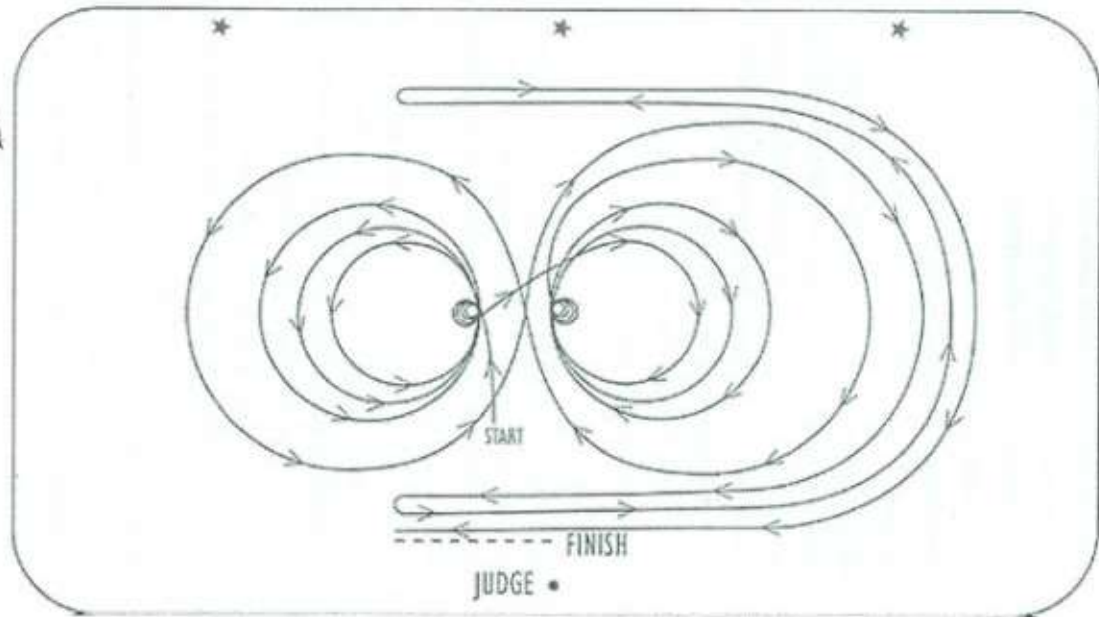

Pattern Provided by: *Wyoming 4-H*

# Wyoming 4-H

## Reining (Senior) -2

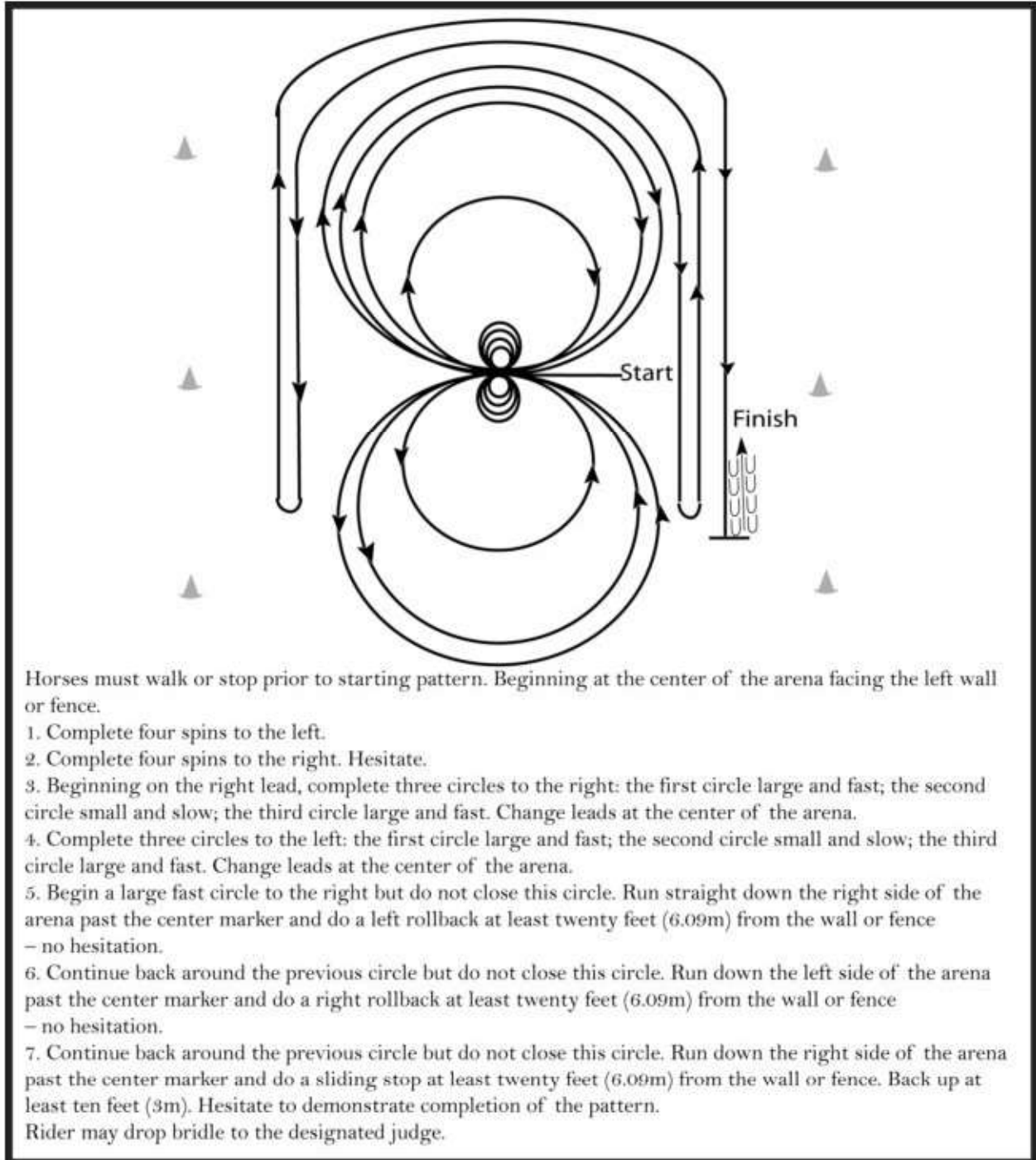

**Pattern Provided by:**

*Wyoming 4-H*

# Wyoming 4-H

## Reining (Senior) -3

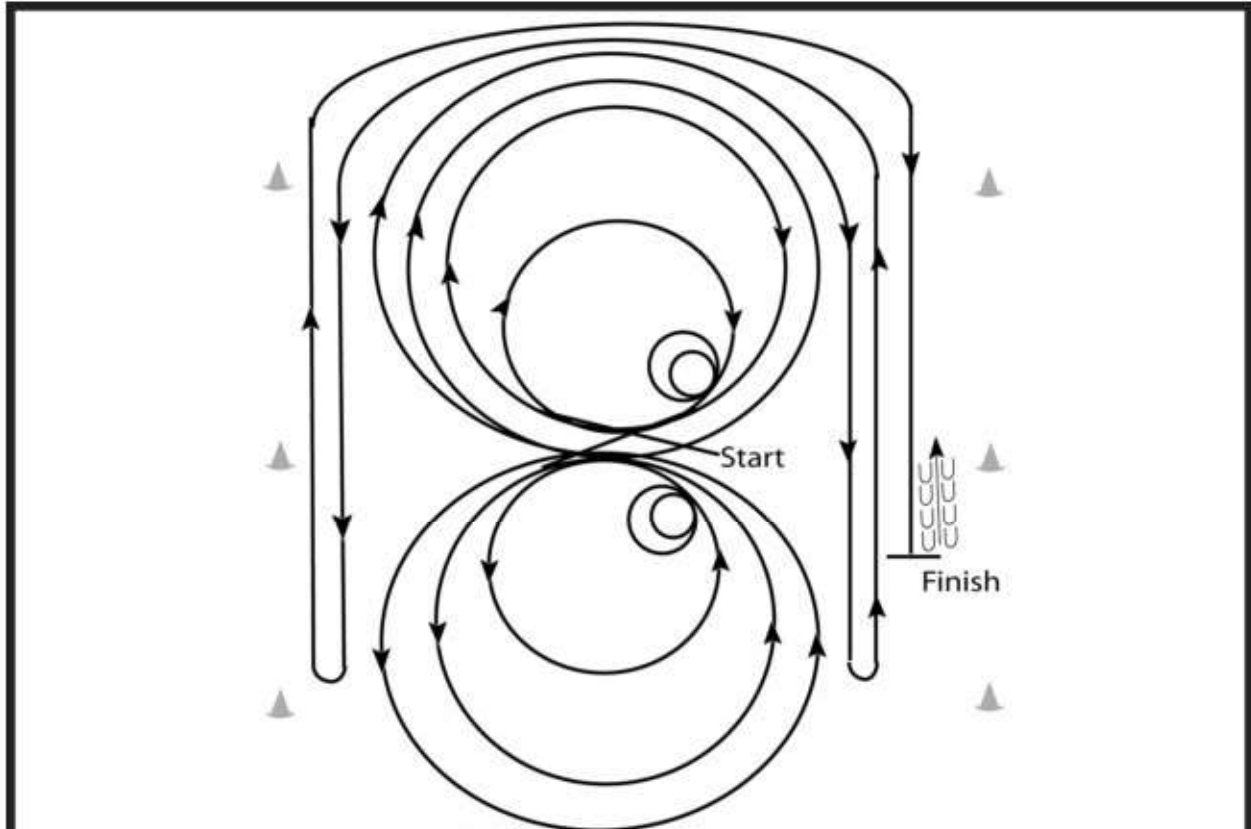

Horses must walk or stop prior to starting pattern.

1. Starting at the center marker make a large fast circle to right on the right lead.
2. Draw the circle down to a small circle until you reach the center marker; stop.
3. Do a double spin to the inside of the small circle at the center marker; at end of spins horse should be facing the left wall, slight hesitation.
4. Begin on the left lead and make a large fast circle.
5. Then a small, slow circle, again drawing it down to the center of the arena, stop, no hesitation on these stops.
6. Do a double spin to the inside of the circle, slight hesitation, horse to be facing left wall.
7. Take a right lead and make a fast figure eight over the large circles, close the eight, and change leads.
8. Begin a large fast circle to the right but do not close this circle. Run down the right side of the arena past the marker and do a left roll back at least 20 feet (6 meters) from the wall or fence - no hesitation.
9. Continue back around the previous circle but do not close this circle. Run down the left side of the arena past the center and do a right roll back at least 20 feet (6 meters) from the wall or fence - no hesitation.
10. Continue back around previous circle but not close this circle. Run down the right side of the arena past the center marker and do a sliding stop at least 20 feet (6 meters) from the wall or fence. Back up at least 10 feet (3 meters). Hesitate to show completion of pattern.

Rider may dismount and drop bridle to the designated judge.

**Pattern Provided by:**

*Wyoming 4-H*

# Wyoming 4-H

## Reining (Senior) -4

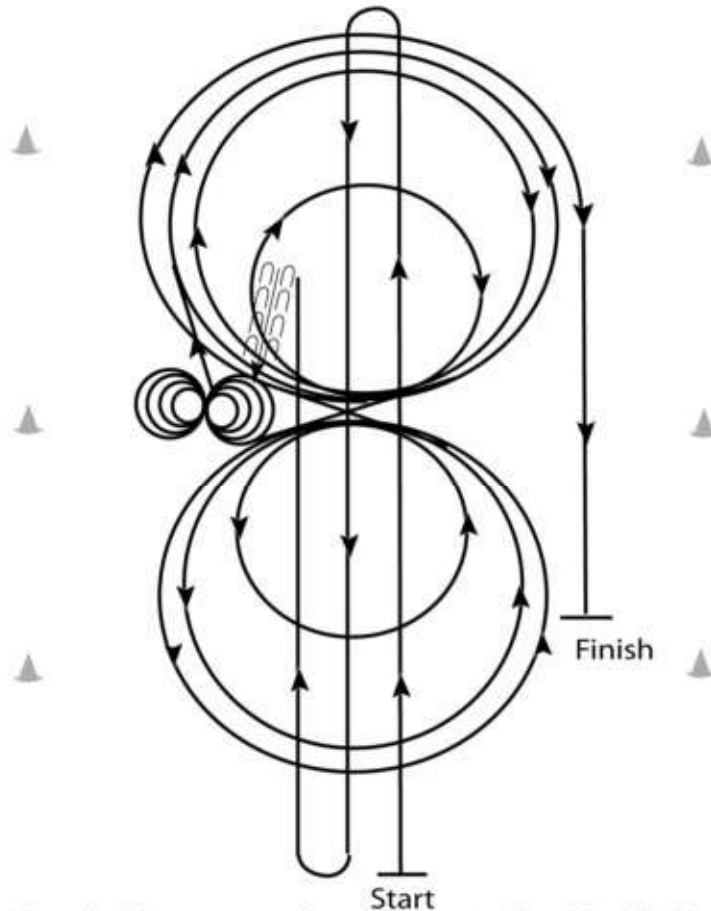

1. Run at speed to the far end of the arena past the end marker and do a left rollback – no hesitation.
2. Run to the opposite end of the arena past the end marker and do a right rollback – no hesitation.
3. Run past the center marker and do a sliding stop. Back up to the center of the arena at least ten feet (3m). Hesitate.
4. Complete four spins to the right.
5. Complete four and one-quarter spins to the left so that horse is facing left wall or fence. Hesitate.
6. Beginning on the right lead, complete three circles to the right: the first two circles large and fast; the third circle small and slow. Change leads at the center of the arena.
7. Complete three circles to the left: the first two circles large and fast; the third circle small and slow. Change leads at the center of the arena.
8. Begin a large fast circle to the right but do not close this circle. Run straight down the right side of the arena past the center marker and do a sliding stop at least twenty feet (6.09m) from the wall or fence. Hesitate to demonstrate completion of the pattern.  
Rider may drop bridle to the designated judge.

**Pattern Provided by:**

*Wyoming 4-H*

# Wyoming 4-H

## Reining (Senior) -5

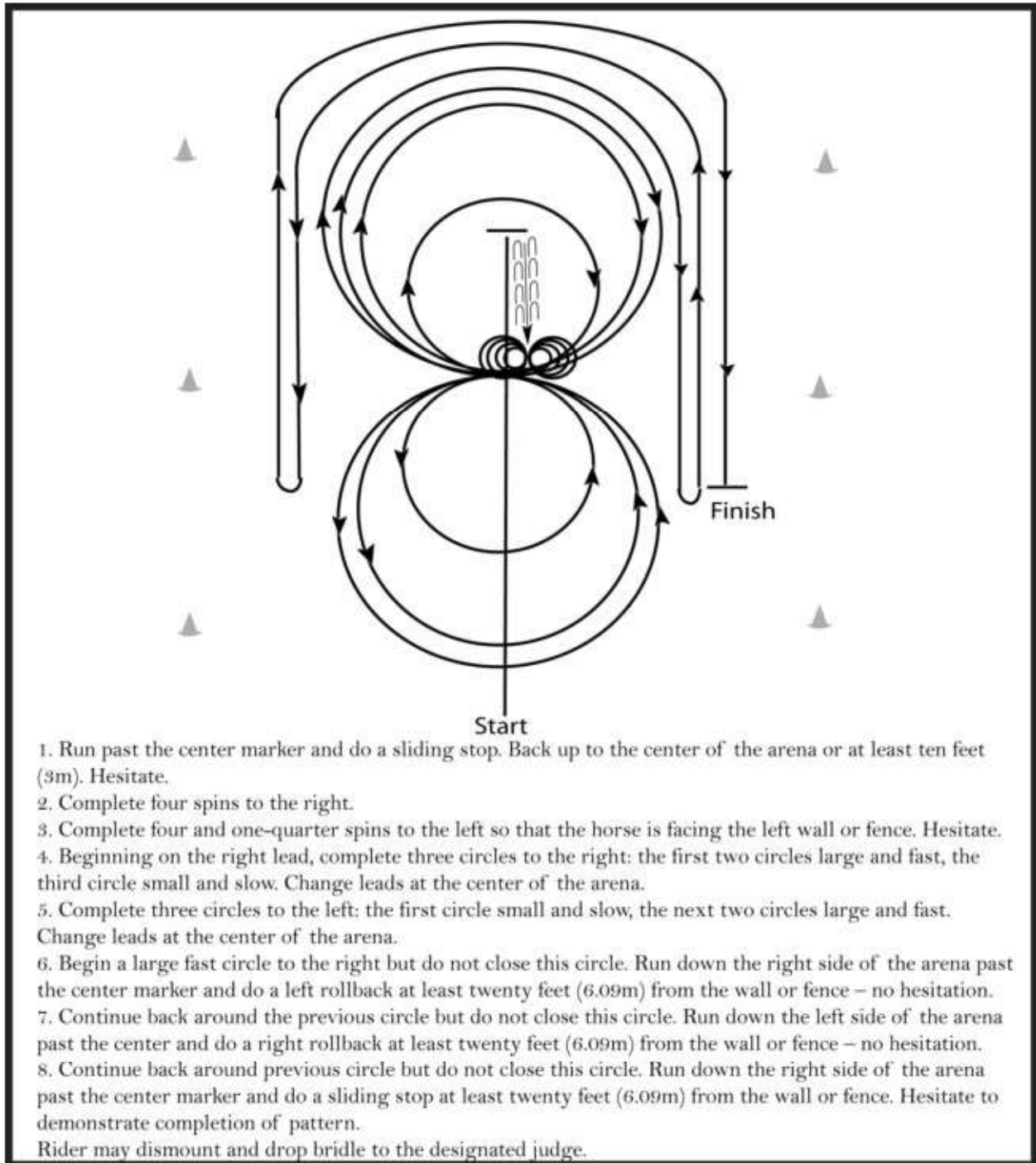

**Pattern Provided by:**

*Wyoming 4-H*

# Wyoming 4-H

## Reining (Senior) -3

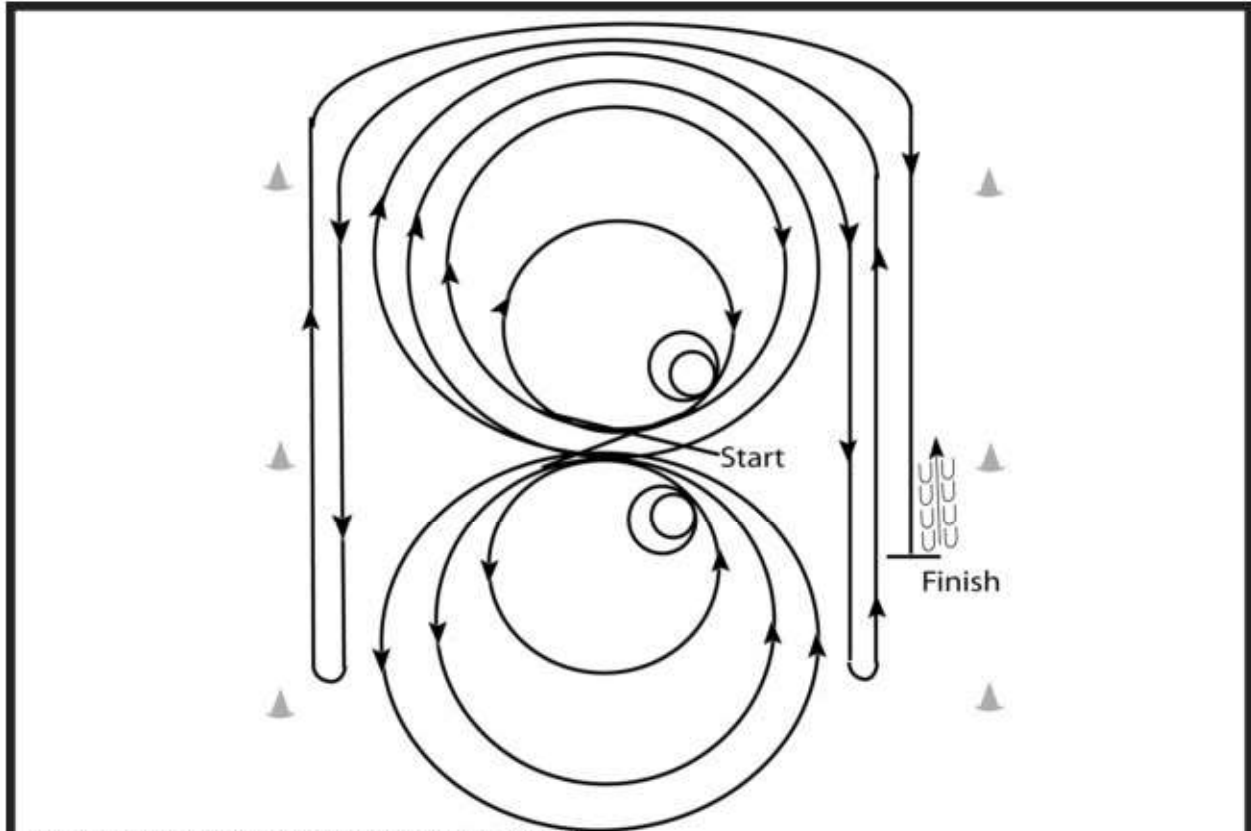

Horses must walk or stop prior to starting pattern.

1. Starting at the center marker make a large fast circle to right on the right lead.
2. Draw the circle down to a small circle until you reach the center marker; stop.
3. Do a double spin to the inside of the small circle at the center marker; at end of spins horse should be facing the left wall, slight hesitation.
4. Begin on the left lead and make a large fast circle.
5. Then a small, slow circle, again drawing it down to the center of the arena, stop, no hesitation on these stops.
6. Do a double spin to the inside of the circle, slight hesitation, horse to be facing left wall.
7. Take a right lead and make a fast figure eight over the large circles, close the eight, and change leads.
8. Begin a large fast circle to the right but do not close this circle. Run down the right side of the arena past the marker and do a left roll back at least 20 feet (6 meters) from the wall or fence - no hesitation.
9. Continue back around the previous circle but do not close this circle. Run down the left side of the arena past the center and do a right roll back at least 20 feet (6 meters) from the wall or fence - no hesitation.
10. Continue back around previous circle but not close this circle. Run down the right side of the arena past the center marker and do a sliding stop at least 20 feet (6 meters) from the wall or fence. Back up at least 10 feet (3 meters). Hesitate to show completion of pattern.

Rider may dismount and drop bridle to the designated judge.

**Pattern Provided by:**

*Wyoming 4-H*